

XCG Series Colour Models

Digital Video
Camera Module



IMAGE SENSING SOLUTIONS

Sony proudly introduces two new raw color GigE cameras to its popular XCG Series: the high-quality, high-performance XCG-5005CR and XCG-U100CR.



XCG-U100CR
2 Mega Raw Colour



XCG-5005CR
5 Mega Raw Colour

Key Features

■ GigE Vision Interface

The adoption of the GigE Vision interface (Ver. 1.2) adds to the outstanding value and performance of the XCG-5005CR and the XCG-U100CR cameras. Answering the growing demand for large-scale systems, they can transfer large amounts of data over long distances (up to 100 meters). In addition, the overall cost of a vision system can be reduced with these cameras thanks to the availability of a variety of peripheral devices.

■ High Frame Rate Image Transfer

The XCG-5005CR and the XCG-U100CR cameras feature a high readout rate of uncompressed images for smooth and clear results. The XCG-5005CR achieves 15fps and the XCG-U100CR achieves 27fps.

These cameras incorporate the GigE Vision® interface, which is specifically standardized for machine-vision applications based on Gigabit Ethernet technology.

In accordance with the growing demand for large-scale systems, this interface enables the cameras to transfer a large amount of data over long distances. The use of an Ethernet cable and the availability of a wide variety of peripheral devices contribute to significant cost-cutting benefits when designing a complete vision system.

The new XCG cameras use a CCD with a color mask (commonly called a "Bayer filter") and output the "raw color" pixel values in 8, 10 or 12 bit to be converted to a color image on a computer. The color conversion that takes place in the computer is supported by Sony's XCG-Software and a variety of commercially available third-party software programs.

In addition, the XCG-5005CR and the XCG-U100CR cameras offer unique benefits that are inherited from the Sony's XCD Series such as Bulk Trigger mode and Sequential Trigger mode.

By utilizing the features and benefits of the GigE Vision interface, the XCG-5005CR and the XCG-U100CR cameras expand the possibilities for intelligent traffic, factory automation, food and beverage inspection, and pharmaceutical applications.

Lineup

	XCG-U100CR	XCG-5005CR
Progressive Scan IT CCD	1/1.8-type	2/3-type
Cell Size (H) x (V)	4.4 x 4.4µm	3.45 x 3.45µm
Standard Picture Size (H) x (V) and Frame Rate	1,600 x 1,200 (UXGA) at 27fps	2,448 x 2,048 at 15fps

Key Features

■ Bulk Trigger Mode/Sequential Trigger Mode

In addition to its conventional trigger mode, the XCG-5005CR and the XCG-U100CR cameras also feature advanced "Bulk Trigger" and "Sequential Trigger" modes. Both cameras support 16 memory channels that can store up to 16 different camera setups (exposure, gain, LUT). "Bulk Trigger" mode allows the XCG cameras to capture up to 16 images in rapid succession using a single software or hardware trigger. "Sequential Trigger" mode allows the camera to capture a single image using successive setups stored in the memory channels with each software or hardware trigger.

■ Low Power Consumption and Compact Design

These compact, lightweight cameras feature low power consumption, and the ability to operate at temperatures of up to 50°C / 122°F

■ High Resistance to Shock and Vibration

Due to their robustness and vibration resistance, the XCG cameras deliver outstanding performance in the most challenging environmental conditions.

Pin assignment

12-pin connector

Pin No.	
1	GND
2	DC IN
3	GND
4	Multi-function output* (TTL)
5	Multi-function output* (ISO-)
6	Multi-function output* (ISO+)
7	GPIO input (ISO+)
8	GND
9	NC
10	NC
11	Trigger input
12	GPIO input (ISO-)

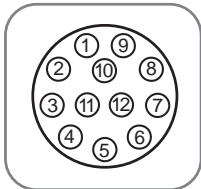

*Multi-function output Exposure output/Strobe control signal/ GPIO output

Optional accessories

Tripod Adaptor	VCT-ST70I
Camera Adaptors	DC-700
	DC-700CE
Cables	CCXC-12P02N
	CCXC-12P05N
	CCXC-12P10N
	CCXC-12P25N

Distributed by

MaxxVision®

Sigmaringer Str. 121
70567 Stuttgart
Tel.: +49 711 997 996 3
Fax: +49 711 997 996 50
www.maxxvision.com
info@maxxvision.com

Specifications

	XCG-U100CR	XCG-5005CR
Camera		
Image sensor	1/1.8-type progressive scan IT CCD	2/3-type progressive scan IT CCD
Standard output pixels	1600 (H) x 1200 (V)	2448 (H) x 2048 (V)
Standard frame rate	27 fps	15 fps
Cell size (H x V)	4.4 x 4.4 μm	3.45 x 3.45 μm
Color filter	Elementary color mosaic	
Minimum illumination	6 lx (F1.4, +18 dB, Shutter: off, 50% video level)	6 lx (F1.4, +18 dB, Shutter: off, 50% video level)
Sensitivity	2000 lx at F5.6 (0 dB)	2000 lx at F8 (0 dB)
Gain	Auto/Manual (0 dB to +18 dB)	
Shutter speed	2 sec to 1/100,000 sec	
Camera Features		
Video output resolution depth	RAW 8: 8 bits/pixel RAW 10: 10 bits/pixel RAW 12: 12 bits/pixels	
Readout modes	Normal, Partial scan	
White balance	One Push WB, Manual	
Readout features	Gamma (variable), Built-in test pattern	
Synchronization	Hardware trigger / Software trigger, Trigger start / Trigger start and exposure duration, Bulk / Sequential trigger mode, Trigger inhibit setting, Trigger delay setting/Strobe control	
Memory channel	16 channels for parameter settings	
User memory	1024 Byte	
Interfaces		
Video output	Gigabit Ethernet(1000Base-T)	
Digital I/Os	ISO IN (1x), ISO OUT (1x), TTL OUT (1x)	
General		
Lens mount	C mount	
Power requirements	DC +12 V (+10.5 V to +15.0 V)	
Power consumption	3.5 W	4.3 W
Operating temperature	-10°C to +50°C (14°F to 122°F)	
Storage temperature	-30°C to +60°C (-22°F to +140°F)	
Operating humidity	20% to 80% (no condensation)	
Storage humidity	20% to 95% (no condensation)	
Vibration resistance	10 G (20 Hz to 200 Hz)	
Shock resistance	70 G	
Dimensions (W x H x D)	44 x 33 x 67.5 mm (1 3/4 x 1 5/16 x 2 3/4 inches) (not including protruding parts)	
Mass	145 g (5.1 oz)	
Regulations	UL2044, FCC Class A, CE: EN55022, AS/NZ: EN55022, VCCI: Class A	

Dimensions Unit: mm (inches)

XCG-U100CR & XCG-5005CR Models

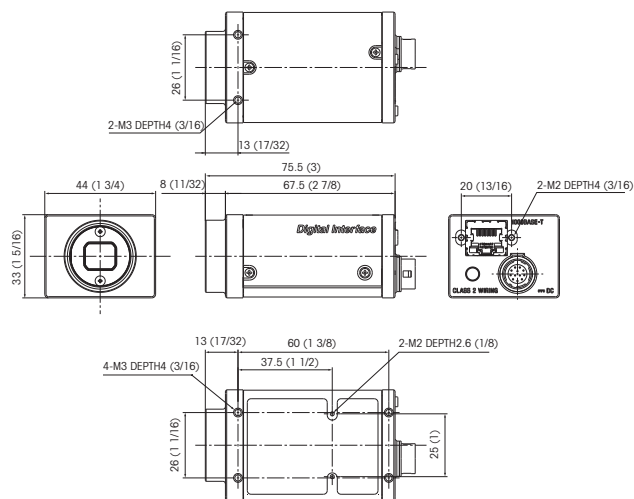

© 2012 Sony Corporation. All rights reserved. Reproduction in whole or in part without written permission is prohibited. Features and specifications are subject to change without notice. The values for mass and dimension are approximate. "Sony" and "make.believe" are trademarks of Sony Corporation. VISCA is a trademark of Sony Corporation. All other properties are the property of their respective owners.

PHC_25/10/12

GEN<i>i>CAM **GiGE™**
VISION

SONY
make.believe