

MVL-MY-2-110-MP

2x 110mm 2/3" TELECENTRIC LENS

MY series Telecentric Lens are designed for machine vision application with excellent imaging quality, magnification range from 0.18x to 6.0x, working distance range from 65 mm to 510 mm, optional point light interface.



Key Features

- High resolution and uniformity of image definition
- Low optical distortion and high telecentricity, more suitable for high precision measurement application
- Excellent anti-vibration performance and stability performance in temperature variation
- Image size compatible with 2/3"

Dimension

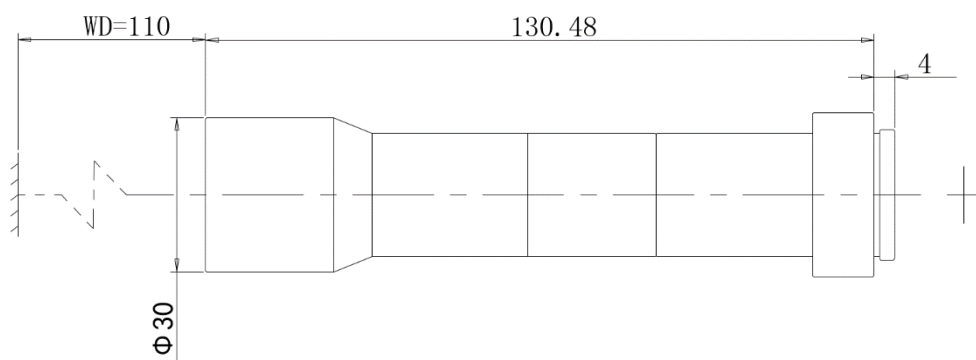

Unit:mm



Specification

	Model	MVL-MY-2-110-MP
Parameter		2x 110mm 2/3" TELECENTRIC LENS
Performance		
Magnification		2
Working Distance		110±2 mm
F-Number		F13.6
Image Size		Φ11 mm
Optical Distortion		≤ 0.05%
Depth of Field*		0.27 mm
Resolution		4.5 μm
Telecentricity		≤ 0.1°
Object Space NA		0.07353
Object Field of View		1/2": D: 4 mm, H: 3.07 mm, V: 2.46 mm 1/1.8": D: 4.5 mm, H: 3.69 mm, V: 2.46 mm 2/3": D: 5.5 mm, H: 4.22 mm, V: 3.54 mm
Mechanical		
Mount		C-Mount
Object-image Distance		258.0 ± 2 mm
Dimension		Φ30 mm × 130.5 mm
Weight		150 g
Temperature		-10 ~ 50°C
General		
Certification		RoHS2.0

*The Depth of Field is the theoretical calculated value when the diameter of the maximum confusion circle is 40 μm.

HIKROBOT

Hangzhou Hikrobot Technology Co., Ltd.
No.399 Danfeng Road, Binjiang District, Hangzhou 310051, China.
en.hikrobotics.com

MaxxVision®

Sigmaringer Str. 121
70567 Stuttgart
Tel.: 0711 997 996 3
www.maxxvision.com

Copyright Hikrobot

Hangzhou Hikrobot Technology Co., Ltd. All Rights Reserved. Hangzhou Hikrobot Technology does not tolerate any infringement. Any organization or individual may not imitate or reproduce in whole or in part of the content. The data herein is based on Hikrobot's internal evaluation. Actual data may vary depending on specific configuration and operating condition. The information herein is subject to change without notice. All the content has been checked conscientiously. Nevertheless, Hikrobot shall not be liable to damages resulting from errors, inconsistencies or omissions.