

**MVL-HF0628-05S**

**6mm F2.8 M12 Mount Lens**

M12 lens series is designed for industry environment with excellent image quality and stability. Adapt for measurement, positioning, defect detection, code scanning and other industrial applications.



**Specification**

Parameter	MVL-HF0628-05S		
	6mm F2.8 M12 Mount Lens		
Focal Length	6mm	Mount	M12*0.5
F-Number	2.8	Relative Illumination	60%
TV Distortion	< 0.5%	Image Size	Φ8.86mm
TTL	28.4~28.9mm	Working Distance Range	100~850mm
Dimension	Φ20mm × 22.5mm	Working Temperature	0~50°C
Field of View	1/1.8"	D (8.86mm)	73°
		H (7.37mm)	63°
		V (4.91mm)	45°

**Dimension**

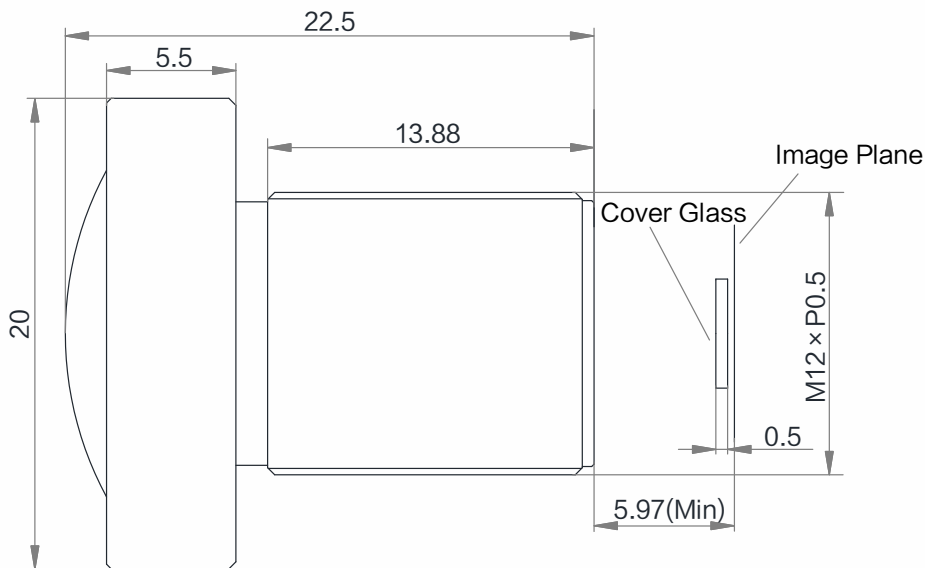

Unit: mm