

MVL-MF0824M-5MPE
2/3" 8mm 5MP FA LENS

MF-E series FA Lens are optimized for machine vision light sources and sensors, with high resolution, excellent image uniformity, high transmittance and good stability. Featured with fixed focal length, manual aperture and compact size, it is suitable for machine vision industry applications.



Key Features

- High resolution and consistency of image clarity
- Lower distortion and higher relative illumination rate
- Achromatic optical system design, Better imaging performance with color camera
- Excellent performance at high and low temperature
- Good optical performance at ultra-short working distance

Distortion

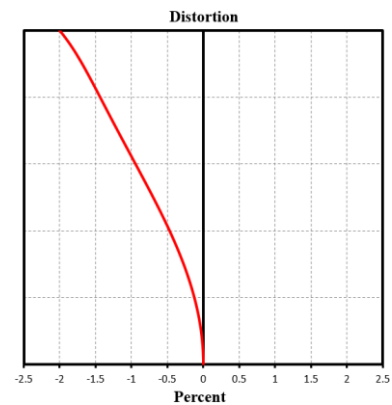

MTF

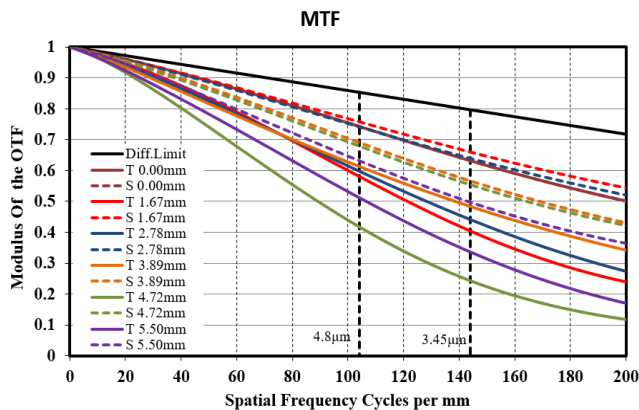

Relative Illumination

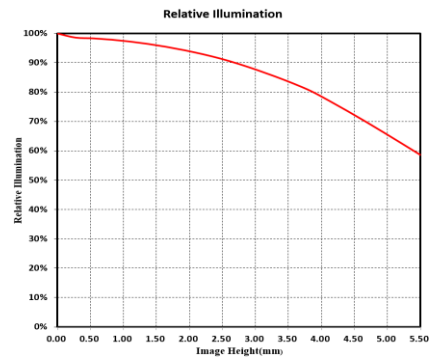

Note: The above curves are the simulate results based on F2.4, $\beta=-0.025$, WD=300 mm



Specification

Model	MVL-MF0824M-5MPE
Parameter	Fixed focal length, Manual iris, 5MP, FA Lens
Performance	
Focal Length	8 mm
F-Number	F2.4 ~ F16
Image Size	Φ11 mm (2/3")
Distortion	2.03%
Minimum Operation Distance	0.1 m
Field of View	D (11.1 mm): 69.46° H (8.45 mm): 55.57° V (7.07 mm): 41.68°
Mechanical	
Iris Control	Manual
Focus Control	Manual
Filter Thread	M35.5 × 0.5
Mount	C-Mount
Flange Back Length	17.526 mm
Dimension	Φ37 × 43.7~45.7 mm
Weight	87.3 g
Temperature	-10 ~ 50°C
General	
Certification	RoHS2.0

Dimension

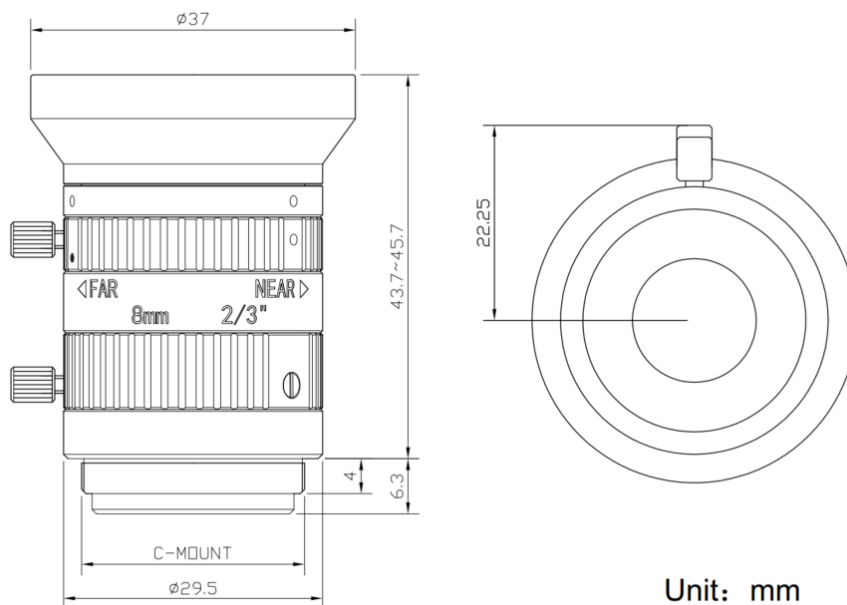

Unit: mm

Field of View

Extension (mm)	Working Distance (mm)		Magnification	Field of View(mm)					
				2/3"		1/1.8"		1/2"	
				H(8.45mm)	V(7.07mm)	H(7.38mm)	V(4.92mm)	H(6.22mm)	V(4.67mm)
2	near	8.1	-0.313	28.7	23.6	24.7	16.1	20.6	15.2
	far	17.9	-0.234	37.8	31.2	32.7	21.4	27.3	20.3
1	near	25.0	-0.186	47.4	39.1	41.0	26.8	34.2	25.4
	far	54.2	-0.114	76.3	63.3	66.2	43.6	55.5	41.4
0		100	-0.066	130.0	108.0	113.0	74.0	94.0	71.0
		150	-0.051	170.0	130.0	140.0	105.0	120.0	90.0
		200	-0.039	225.0	177.0	185.0	139.0	160.0	120.0
		250	-0.030	280.0	215.0	242.0	170.0	200.0	150.0
		300	-0.025	341.0	285.0	297.0	197.0	250.0	187.0
		350	-0.022	394.0	329.0	344.0	228.0	289.0	216.0
		400	-0.019	440.0	373.0	390.0	258.0	328.0	245.0
		450	-0.017	495.0	417.0	436.0	289.0	366.0	274.0
		500	-0.015	550.0	462.0	482.0	320.0	405.0	303.0
		550	-0.014	605.0	506.0	528.0	350.0	444.0	330.0
		600	-0.013	660.0	550.0	574.0	381.0	483.0	360.0
		650	-0.012	715.0	594.0	621.0	412.0	522.0	390.0
		700	-0.011	770.0	638.0	667.0	442.0	561.0	420.0
		800	-0.010	880.0	727.0	760.0	504.0	638.0	478.0
	900	-0.009	990.0	815.0	852.0	565.0	716.0	536.0	
	1000	-0.008	1100.0	904.0	944.0	626.0	794.0	594.0	

HIKROBOT

Hangzhou Hikrobot Co. Ltd.
en.hikrobotics.com

MaxxVision®

Sigmaringer Str. 121
70567 Stuttgart

Tel.: 0711 997 996 3

www.maxxvision.com

© Hangzhou Hikrobot Co., Ltd. All Rights Reserved.

Hangzhou Hikrobot does not tolerate any infringement. Any organization or individual may not imitate or reproduce in whole or in part of the content. The data herein is based on Hikrobot's internal evaluation. Actual data may vary depending on specific configuration and operating condition. The information herein is subject to change without notice. All the content has been checked conscientiously. Nevertheless, Hikrobot shall not be liable to damages resulting from errors, inconsistencies or omissions.