

MVL-KF1224M-25MP
1.2" 12mm 25MP FA LENS

KF-P series FA Lens are optimized for machine vision light sources and sensors, with high resolution, excellent image uniformity, high transmittance and good stability. Featured with fixed focal length, manual aperture and compact size, it is suitable for machine vision industry applications.



Key Features

- Ultra high resolution and consistency of image clarity
- 1.2" image Format, bigger aperture, lower distortion, Higher illumination relative
- Achromatic optical system design, Better imaging performance with color camera
- Maintain excellent optical properties at different object distances
- Excellent vibration resistance and stability at high and low temperature performance, optical axis shifting within pixel level
- Multilayer and broadband coating design, compatible with visible and near infrared applications

Distortion

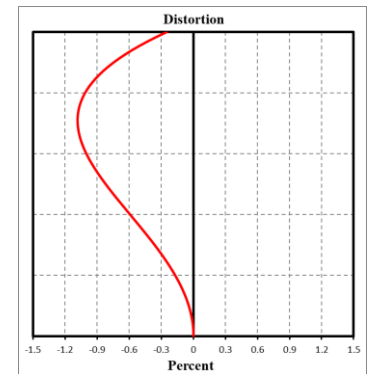

MTF

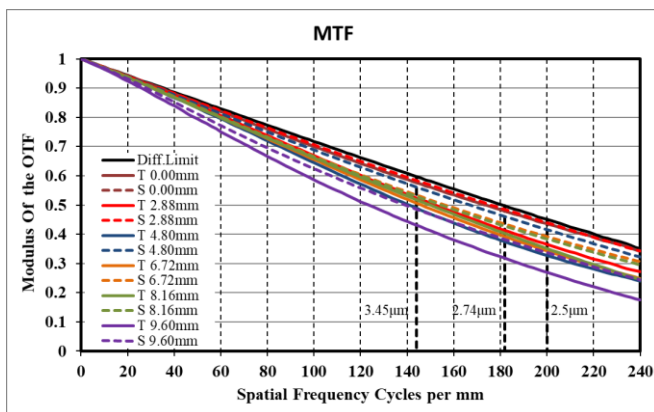

Relative Illumination

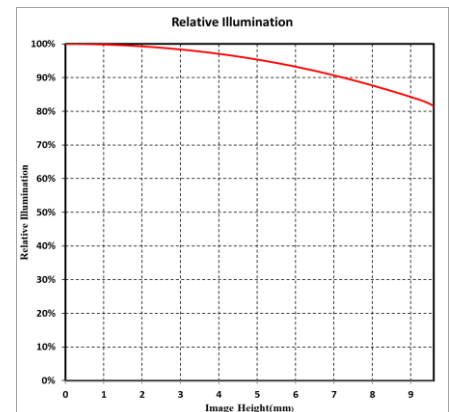

Note: The above curves are the simulate results based on F4, $\beta=-0.037$, WD=300 mm



Specification

Model	MVL-KF1224M-25MP
Parameter	Fixed focal length, Manual iris, 25MP, FA Lens
Performance	
Focal Length	12 mm
F-Number	F2.4 ~ F16
Image Size	Φ19.3 mm(1.2")
Distortion	0.39%
Minimum Operation Distance	0.1 m
Field of View	D (19.30mm): 76.37° H (14.60mm): 62.32° V (12.63mm): 55.34°
Mechanical	
Iris Control	Manual
Focus Control	Manual
Mount	C-Mount
Flange Back Length	17.526 mm
Dimension	Φ50 × 66.96 mm
Weight	215 g
Temperature	-10 ~ 50°C
General	
Certification	RoHS2.0

Dimension

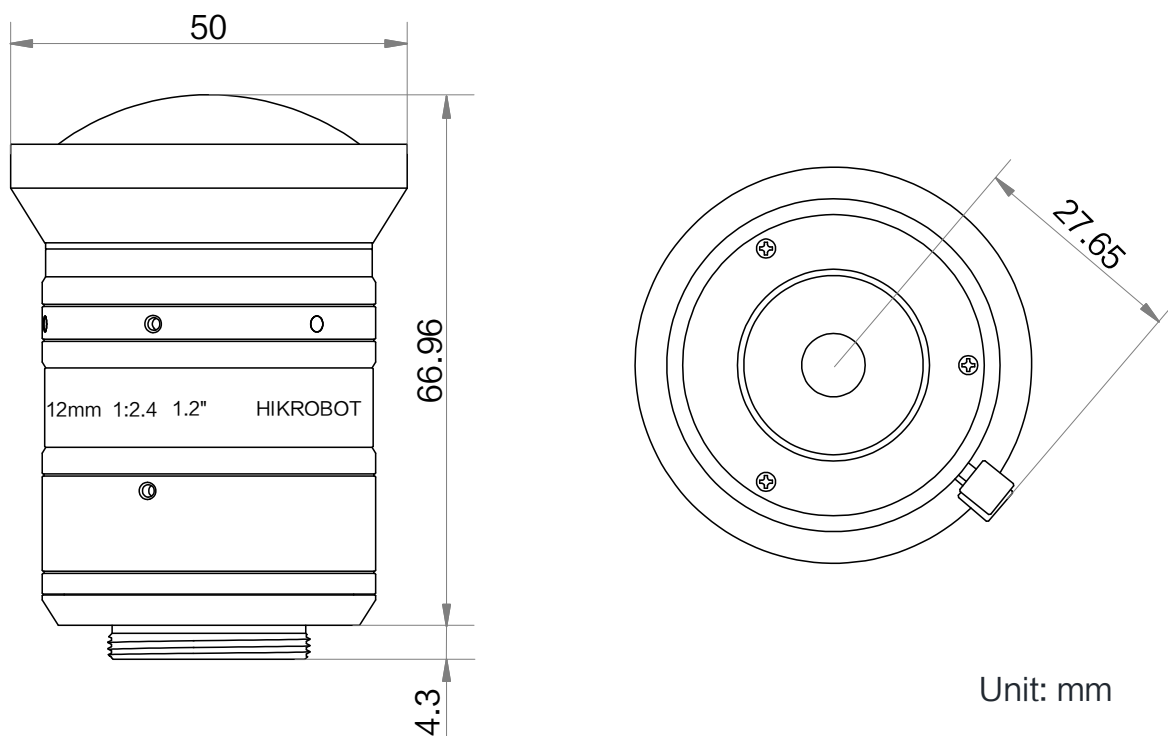

Unit: mm

Field of View

Extension (mm)	Working Distance (mm)		Magnification	Field of View (mm)					
				1.2"		1.1"		2/3"	
				H (14.6mm)	V (12.63mm)	H (14.14mm)	V (10.35mm)	H (8.45mm)	V (7.07mm)
1	near	43.80	-0.18	84.33	72.37	81.52	58.78	47.68	39.72
	far	96.06	-0.101	148.49	127.87	143.67	104.19	84.67	70.62
0		100	-0.098	153.00	131.92	148.08	107.62	87.51	73.03
		150	-0.069	214.03	184.81	207.22	150.95	122.86	102.56
		200	-0.054	274.92	237.59	266.23	194.21	158.14	132.05
		250	-0.044	335.76	290.33	325.19	237.43	193.39	161.51
		300	-0.037	396.56	343.04	384.12	280.64	228.63	190.97
		350	-0.032	457.34	395.73	443.03	323.83	263.86	220.42
		400	-0.028	518.12	448.42	501.93	367.02	299.09	249.86
		450	-0.025	578.88	501.10	560.82	410.20	334.31	279.30
		500	-0.023	639.64	553.77	619.71	453.38	369.52	308.73
		550	-0.021	700.39	606.44	678.59	496.55	404.74	338.17
		600	-0.019	761.14	659.11	737.46	539.72	439.96	367.60
		650	-0.018	821.89	711.78	796.34	582.89	475.17	397.04
		700	-0.017	882.64	764.44	855.21	626.06	510.38	426.47
		800	-0.015	1004.12	869.77	972.96	712.40	580.80	485.33
		900	-0.013	1125.60	975.09	1090.69	798.74	651.22	544.19
	1000	-0.012	1247.08	1080.41	1208.43	885.07	721.64	603.05	

HIKROBOT

Hangzhou Hikrobot Co. Ltd.
en.hikrobotics.com

MaxxVision®

Sigmaringer Str. 121
70567 Stuttgart
Tel.: 0711 997 996 3
www.maxxvision.com

© Hangzhou Hikrobot Co., Ltd. All Rights Reserved.

Hangzhou Hikrobot does not tolerate any infringement. Any organization or individual may not imitate or reproduce in whole or in part of the content. The data herein is based on Hikrobot's internal evaluation. Actual data may vary depending on specific configuration and operating condition. The information herein is subject to change without notice. All the content has been checked conscientiously. Nevertheless, Hikrobot shall not be liable to damages resulting from errors, inconsistencies or omissions.