

V5028-MPY

f=50mm F2.8

for 1.1" type 12 Megapixel cameras, Fixed-focal

C-Mount

Model No.	V5028-MPY		Effective	Front	ϕ 22.2mm		
Focal Length	50mm		Lens Aperture	Rear	ϕ 15.4mm		
Max. Aperture Ratio	1:2.8		Distortion	1.1 type	0.1%		
Max. Image Format	14.2mm x 10.4mm(ϕ 17.6mm)			1 type	0.1%		
Operation Range	Iris	F2.8 - F16.0		2/3 type	0.1%		
	Focus	0.5m - Inf.	Back Focal Length		11.9mm		
Control	Iris	Manual	Flange Back Length		17.526mm		
	Focus	Manual	Mount		C-Mount		
Object Dimension at M.O.D.	1.1 Type	12cm x 8.5cm	Filter Size		M34.0 P=0.5mm		
	1 Type	10cm x 7.8cm	Dimensions		ϕ 39.5mm x 45.2mm		
	2/3 Type	7.2cm x 5.4cm	Weight		107.0g		
Angle of View	D	1.1 Type	20.0°	1 Type	18.2°	2/3 Type	12.6°
	H		16.2°		14.6°		10.1°
	V		11.9°		11.0°		7.6°
Operating Temperature	-10°C - +50°C						

M.O.D. : Minimum Object Distance

Dimensions

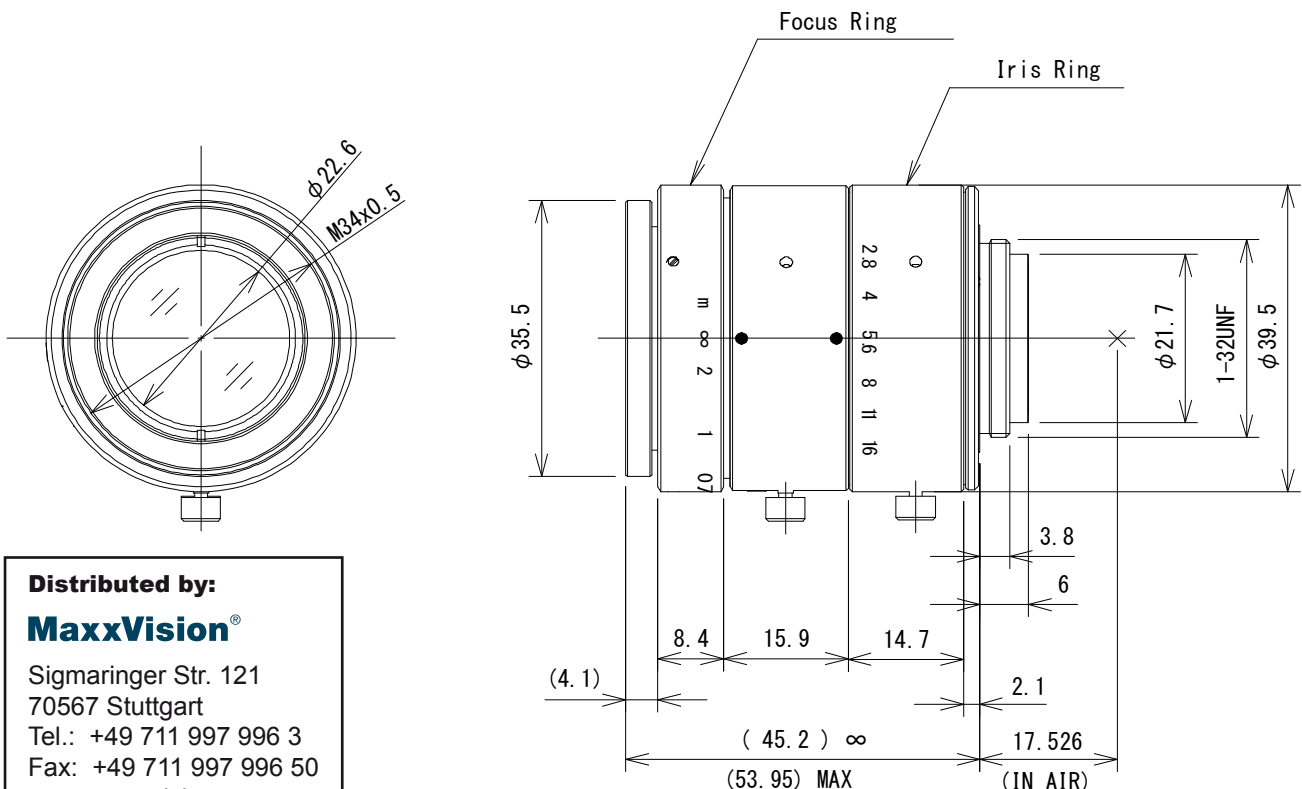

Distributed by:
MaxxVision®
 Sigmaringer Str. 121
 70567 Stuttgart
 Tel.: +49 711 997 996 3
 Fax: +49 711 997 996 50
 www.maxxvision.com
 info@maxxvision.com