

V3528-MPY

f=35mm F2.8

for 1.1" type 12 Megapixel cameras, Fixed-focal

C-Mount

Model No.	V3528-MPY		Effective	Front	φ 20.9mm		
Focal Length	35mm		Lens Aperture	Rear	φ 14.3mm		
Max. Aperture Ratio	1:2.8		Distortion	1.1 type	-0.1%		
Max. Image Format	14.2mm x 10.4mm(φ 17.6mm)			1 type	0.0%		
Operation Range	Iris	F2.8 - F16.0		2/3 type	0.0%		
	Focus	0.3m - Inf.	Back Focal Length		11.7mm		
Control	Iris	Manual	Flange Back Length		17.526mm		
	Focus	Manual	Mount		C-Mount		
Object Dimension at M.O.D.	1.1 Type	11cm x 8cm	Filter Size		M34.0 P=0.5mm		
	1 Type	10cm x 7cm	Dimensions		φ 39.5mm x 45.2mm		
	2/3 Type	7cm x 5cm	Weight		103.0g		
Angle of View	D	1.1 Type	28.2°	1 Type	25.8°	2/3 Type	17.9°
	H		22.9°		20.7°		14.3°
	V		16.9°		15.6°		10.8°
Operating Temperature	-10°C - +50°C						

M.O.D. : Minimum Object Distance

Dimensions

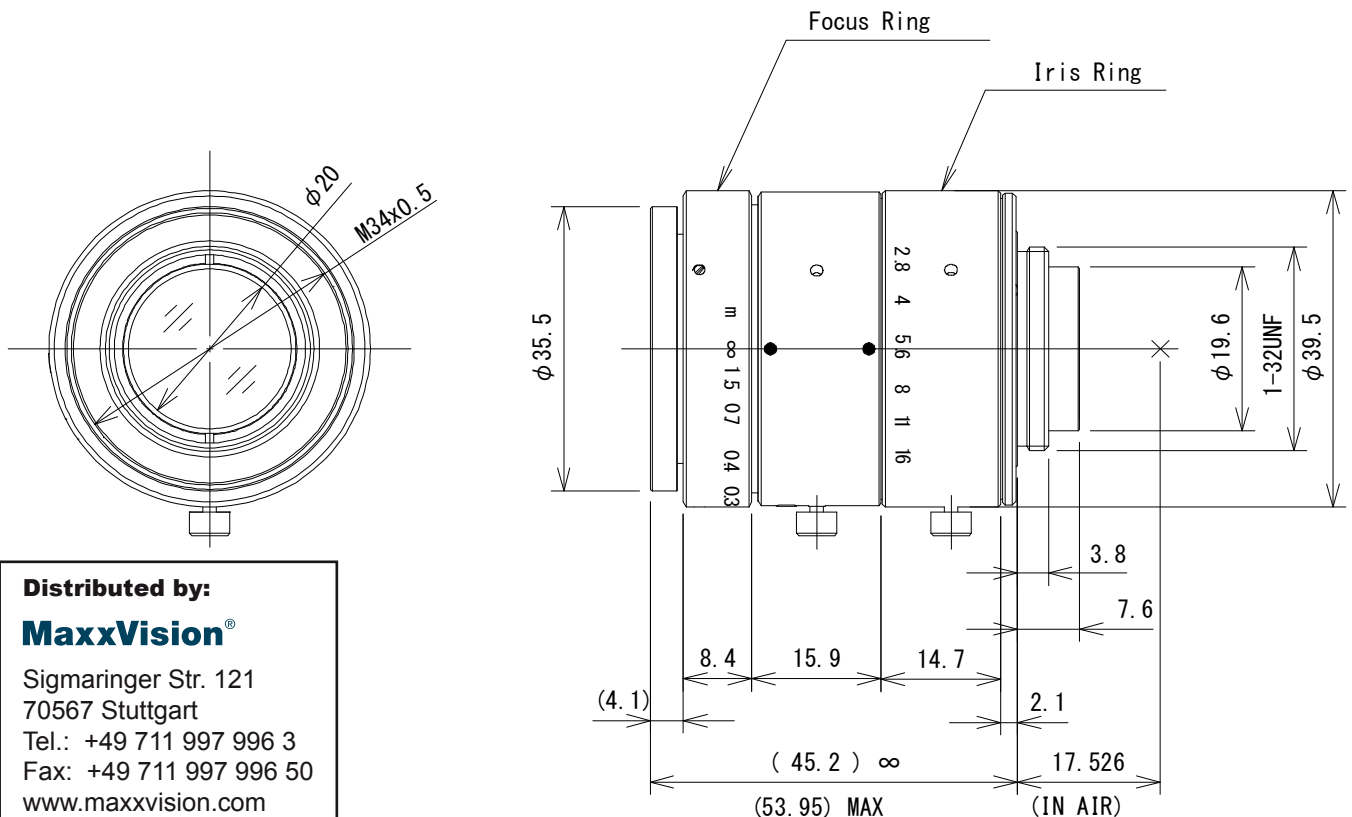

Distributed by:
MaxxVision®
 Sigmaringer Str. 121
 70567 Stuttgart
 Tel.: +49 711 997 996 3
 Fax: +49 711 997 996 50
 www.maxxvision.com
 info@maxxvision.com