

# MV-SC2016EM

## 1.6 MP 1/2.9" Vision Sensor

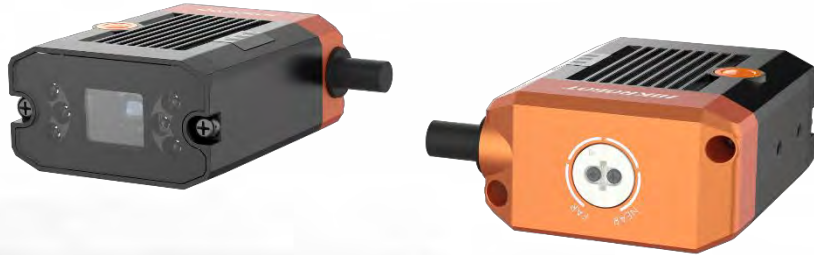

### Introduction

With built-in positioning and measurement algorithms, MV-SC2016EM vision sensor can detect object's existence, count patterns and spots, etc. It can be monitored and operated via the SCMVS client. It can output results via RS-232 and Ethernet, and cooperate with other processes via IO. The vision sensor supports multiple result output methods and customized result text output.

### Key Features

- Adopts embedded hardware platform for high-speed image processing.
- Adopts built-in positioning and measurement algorithms to detect object's existence, count patterns and spots, etc.
- Multiple IO interfaces for input and output signals.
- Multiple indicators for displaying device status.
- Adopts light source to ensure uniform brightness in the illuminated area.
- Supports multiple communication protocols, including Serial Port, TCP, UDP, FTP, Profinet, Modbus, Ethernet/IP, etc.

### Available Model

- 8 mm focal length: MV-SC2016EM-08S-WBN
- 12.4 mm focal length: MV-SC2016EM-12S-WBN
- 14.8 mm focal length: MV-SC2016EM-15S-WBN

### Applicable Industry

Consumer electronics, food and medical industry, automobile, etc.

### Dimension

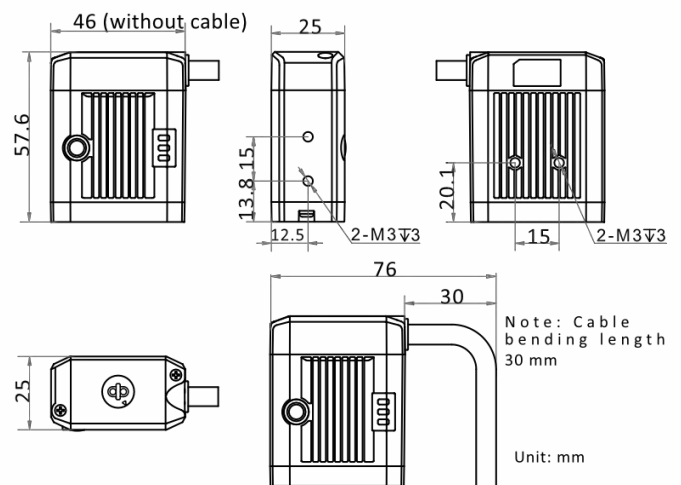

## Specification

Model	MV-SC2016EM-08S-WBN	MV-SC2016EM-12S-WBN	MV-SC2016EM-15S-WBN
<b>Tool</b>			
Vision tool	<ul style="list-style-type: none"> <li>● Existence: Pattern existence, spot existence</li> <li>● Count: Pattern count, spot count</li> <li>● Measurement: Brightness average value, contrast measurement</li> </ul>		
Solution capacity	Supports solution importing and exporting, up to 8 solutions and 40 modules can be stored.		
Communication protocol	Serial Port, TCP, UDP, FTP, Profinet, Modbus, Ethernet/IP		
<b>Camera</b>			
Sensor type	CMOS, global shutter		
Pixel size	3.45 μm × 3.45 μm		
Sensor size	1/2.9"		
Resolution	1408 × 1024		
Max. frame rate	60 fps		
Dynamic range	71.4 dB		
SNR	41 dB		
Gain	0 dB to 15 dB		
Exposure time	16 μs to 1 sec		
Pixel format	Mono 8		
Mono/color	Mono		
<b>Electrical features</b>			
Data interface	Fast Ethernet		
Digital I/O	17-pin M12 connector provides power, Ethernet, serial port, digital I/O, including configurable I/O × 2 (Line 0/1), input signal × 1 (Line 2), output signal × 1 (Line 3), and RS-232 × 1. Device trigger via pressing button supported.		
Power supply	12 VDC to 24 VDC		
Max. power consumption	Approx. 22 W@24 VDC		
<b>Mechanical</b>			
Lens mount	M12-mount, adjusting focus manually supported		
Focal length	8 mm (0.3")	12.4 mm (0.5")	14.8 mm (0.6")
Lens cap	Transparent lens cap		
Light source	White LED lamp		
Indicator	Power indicator (PWR), network indicator (LNK), and status indicator (STS).		
Dimension	46 mm × 57.6 mm × 25 mm (1.8" × 2.3" × 1.0")		
Weight	Approx. 220 g (0.5 lb.)		
Ingress protection	IP65 (under proper installation of lens and wiring)		
Temperature	Working temperature: 0 °C to 50 °C (32 °F to 122 °F) Storage temperature: -30 °C to 70 °C (-22 °F to 158 °F)		
Humidity	20% to 95% RH, non-condensing		
<b>General</b>			
Client software	SCMVS		
Certification	CE, FCC, KC		

## Detection Range

Lens focal length	Installation distance	Field of view	Single pixel accuracy
8 mm (0.3")	80 mm (3.1")	47.62 mm × 34.64 mm (1.9" × 1.4")	0.034 mm
	2000 mm (78.7")	1190.59 mm × 865.88 mm (46.9" × 34.1")	0.846 mm
12.4 mm (0.5")	200 mm (7.9")	78.35 mm × 56.98 mm (3.1" × 2.2")	0.056 mm
	2000 mm (78.7")	783.48 mm × 569.81 mm (30.8" × 22.4")	0.556 mm
14.8 mm (0.6")	270 mm (10.6")	88.62 mm × 64.45 mm (3.5" × 2.5")	0.063 mm
	2000 mm (78.7")	656.43 mm × 477.41 mm (25.8" × 18.8")	0.466 mm

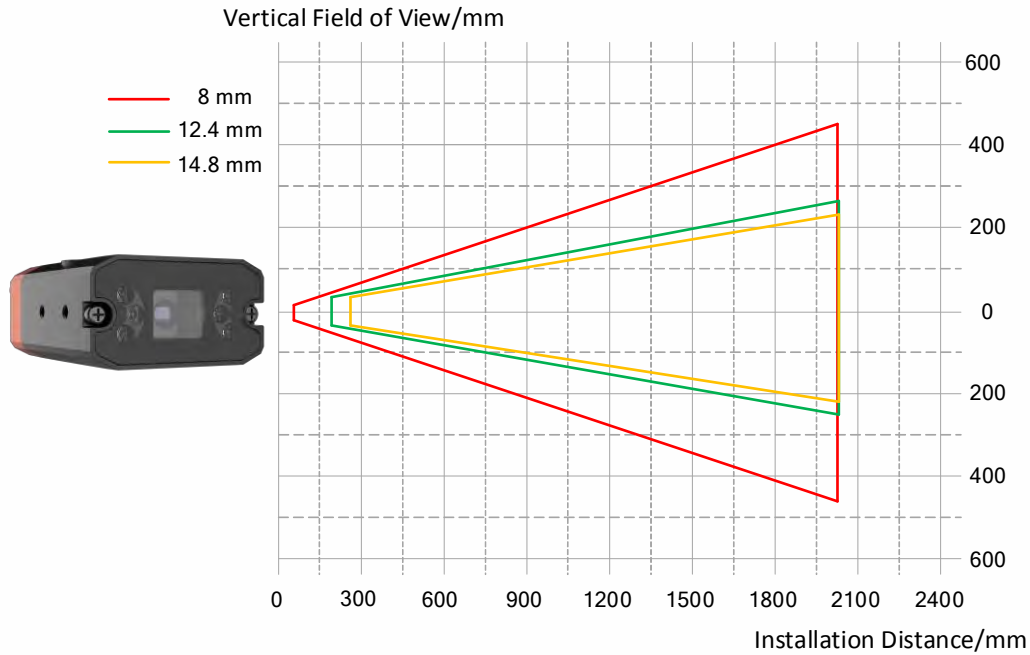

**HIKROBOT**

Hangzhou Hikrobot Technology Co., Ltd.  
No.399 Danfeng Road, Binjiang District, Hangzhou 310051, China.  
en.hikrobotics.com

**MaxxVision®**

Sigmaringer Str. 121  
70567 Stuttgart

Tel.: 0711 997 996 3

[www.maxxvision.com](http://www.maxxvision.com)

Copyright Hikrobot

Hangzhou Hikrobot Technology Co., Ltd. All Rights Reserved. Hangzhou Hikrobot Technology does not tolerate any infringement. Any organization or individual may not imitate or reproduce in whole or in part of the content. The data herein is based on Hikrobot's internal evaluation. Actual data may vary depending on specific configuration and operating condition. The information herein is subject to change without notice. All the content has been checked conscientiously. Nevertheless, Hikrobot shall not be liable to damages resulting from errors, inconsistencies or omissions.