

MV-ID2004M-16T

0.4 MP Smart Code Reader



Introduction

MV-ID2004M-16T smart code reader can read different types of 1-dimensional and 2-dimensional codes, and its max. reading speed reaches 45 codes/sec. It adopts high-speed focus adjustment technology for fast focus adjustment, and is a good selection for the mixed line production.

Key Feature

- Supports high-speed focus adjustment for switching working distance.
- Compact design and small in size, and can be installed in narrow space.
- Adopts LED aiming light to aim targets.
- Adopts multiple IO interfaces and plug-in power interface for easy wiring.
- Supports multiple communication protocols, including TCP, Serial, FTP, etc.

Available Model

MV-ID2004M-16T-RBN

Applicable Industry

Consumer electronics, food and beverage, pharmaceutical, semiconductor, new energy, etc.

Dimension

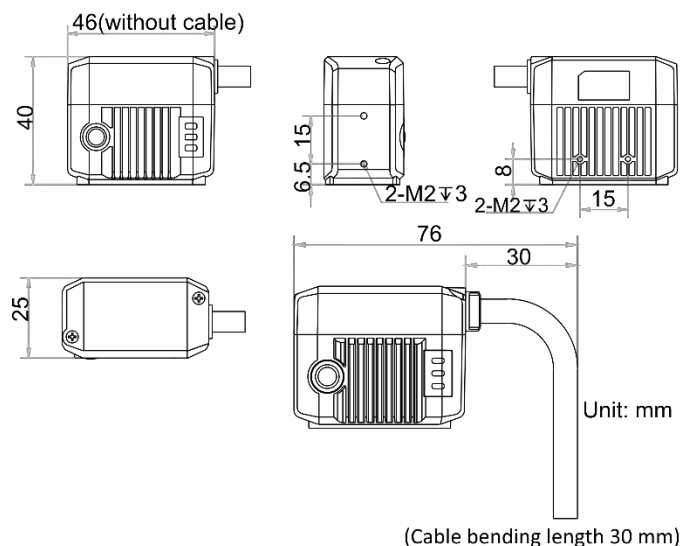

Specification

Model	MV-ID2004M-16T-RBN
Performance	
Symbologies	1-dimensional codes: Code 39, Code 93, Code 128, ITF 14, ITF 25, CodaBar, EAN 8, EAN 13, UPCA, UPCE
	2-dimensional codes: QR Code, Data Matrix
Max. frame rate	60 fps
Max. reading speed	45 codes/sec
Sensor type	CMOS, global shutter
Pixel size	6.9 μm \times 6.9 μm
Sensor size	1/2.9"
Resolution	704 \times 540
Exposure time	16 μs to 1 sec
Gain	0 dB to 40 dB
Mono/color	Mono
Communication protocol	SmartSDK, TCP Client, Serial, FTP, TCP Server, Profinet, MELSEC, Ethernet/IP, ModBus, UDP, Fins, SLMP
Optics	
Focal length	16 mm (0.63")
Working distance	100 mm to 400 mm (3.94" to 15.75")
Ambient illumination	0 lux to 50000 lux
Light source	Red color
Aiming system	Orange LED
Electrical feature	
Data interface	Fast Ethernet
Digital I/O	17-pin M12 connector provides power and I/O, including configurable bi-directional none-isolated I/O \times 2 (Line 0/1), none-isolated input (Line 2) \times 1, none-isolated output (Line 3) \times 1, and RS-232 \times 1. Device trigger via pressing trigger button supported.
Power supply	12 VDC to 24 VDC
Max. power consumption	Approx. 11 W@12 VDC
Mechanical	
Indicator	Power indicator (PWR), network indicator (LNK), and status indicator (STS).
Dimension	46 mm \times 40 mm \times 25 mm (1.81" \times 1.57" \times 0.98")
Weight	Approx. 135 g (0.30 lb.)
Ingress protection	IP65
Temperature	Working temperature: 0 $^{\circ}\text{C}$ to 50 $^{\circ}\text{C}$ (32 $^{\circ}\text{F}$ to 122 $^{\circ}\text{F}$)
	Storage temperature: -30 $^{\circ}\text{C}$ to 70 $^{\circ}\text{C}$ (-22 $^{\circ}\text{F}$ to 158 $^{\circ}\text{F}$)
Humidity	20% to 95% RH, non-condensing
General	
Client software	IDMVS
Certification	CE, RoHS

HIKROBOT

Hangzhou Hikrobot Co., Ltd.
en.hikrobotics.com

MaxxVision[®]

Sigmaringer Str. 121
70567 Stuttgart
Tel.: 0711 997 996 3
www.maxxvision.com

© Hangzhou Hikrobot Co., Ltd. All Rights Reserved.

Hangzhou Hikrobot does not tolerate any infringement. Any organization or individual may not imitate or reproduce in whole or in part of the content. The data herein is based on Hikrobot's internal evaluation. Actual data may vary depending on specific configuration and operating condition. The information herein is subject to change without notice. All the content has been checked conscientiously. Nevertheless, Hikrobot shall not be liable to damages resulting from errors, inconsistencies or omissions.