

MV-CT032G-38GM/GC01

3.2 MP GigE Area Scan Camera



Introduction

Designed for industrial applications, MV-CT032G-38GM/GC01 camera offers industry-leading performance and reliability, with various versions to meet diverse application needs. It supports IP67 protection, expanded interfaces, and integration of liquid/electric lenses, light sources, and lens cap, creating a more flexible and efficient system.

Key Feature

- The devices with PRO version and MAX version support waterproof connector.
- The devices with PRO version and MAX version adopt precision temperature control design for fast heat balance.
- The color devices with PRO version and MAX version support auto color correction based on multi-spectral fusion technology.
- The device with MAX version integrates lens and light source, enabling lens focusing and light source control.
- Adopts GigE interface and max. transmission distance of 100 meters without relay.
- Compatible with GigE Vision V2.0 Protocol, GenlCam Standard, and third-party software based on the protocol and standard.

Applicable Industry

Electronic semiconductor, factory automation, food and beverage, medicine packaging, etc.

Available Model

- Mono camera (BASE):
MV-CT032G-38GM01-BASE
- Color camera (BASE):
MV-CT032G-38GC01-BASE
- Mono camera (PRO):
MV-CT032G-38GM01-PRO
- Color camera (PRO):
MV-CT032G-38GC01-PRO
- Mono camera (MAX):
MV-CT032G-38GM01-MAX
- Color camera (MAX):
MV-CT032G-38GC01-MAX

Sensor Quantum Efficiency

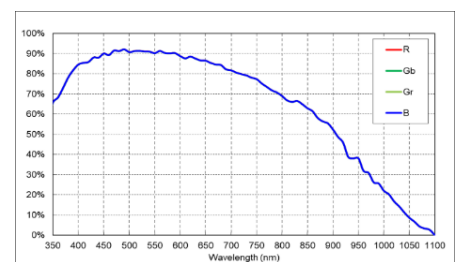

MV-CT032G-38GM01

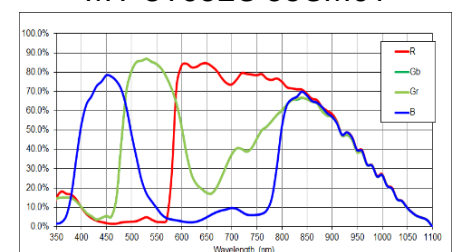

MV-CT032G-38GC01

Specification

Model	MV-CT032G-38GM01	MV-CT032G-38GC01
Performance		
Sensor type	CMOS, global shutter	
Sensor model	Stacked BSI	
Pixel size	3.45 μm \times 3.45 μm	
Sensor size	1/1.8"	
Resolution	2048 \times 1536	
Max. frame rate	39 fps @ 2048 \times 1536 Mono 8 77.5 fps @ 2048 \times 1536 Mono 8 (PRO + MAX: lossless compression mode enabled)	39 fps @ 2048 \times 1536 Bayer GR 8 77.5 fps @ 2048 \times 1536 Bayer GR 8 (PRO + MAX: lossless compression mode enabled)
Dynamic range	73.9 dB	
SNR	42.4 dB	
Gain	High full well capacity: 0 dB to 12.8 dB High sensitivity: 0 dB to 24 dB	
Exposure time	High full well capacity: 30 μs to 10 sec High sensitivity: 5 μs to 10 sec	
Exposure mode	Off/Once/Continuous exposure mode, supports Trigger Width and Trigger Controlled	
Mono/color	Mono	Color
Pixel format	Mono 8/10/10Packed/12/12Packed	Mono 8, Bayer GR 8/10/10Packed/12/12Packed, YUV422Packed, YUV422_YUYV_Packed, RGB 8, BGR 8
Binning	Supports 1 \times 1, 2 \times 2, 4 \times 4	
Decimation	Supports 1 \times 1, 2 \times 2, 4 \times 4	
Reverse image	Supports horizontal and vertical reverse image output	
Electrical features		
Data interface	Gigabit Ethernet (1000 Mbit/s), compatible with Fast Ethernet (100 Mbit/s)	
Data interface type	BASE: RJ45 connector PRO + MAX: 8-pin M12 X-Code waterproof aviation connector	
Control interface	BASE + PRO: Not support MAX: 8-pin M12 A-Code waterproof aviation connector	
Digital I/O	8-pin M8 A-Code aviation connector provides power and I/O, including opto-isolated input \times 1 (Line 0), opto-isolated output \times 1 (Line 1), bi-directional non-isolated I/O \times 1 (Line 2).	
Power supply	9 VDC to 24 VDC, supports PoE	
Power consumption	BASE: Typ. 1.5 W @ 12 VDC PRO: Typ. 1.5 W @ 12 VDC (fast heat balance not enabled) MAX: Typ. 1.6 W @ 24 VDC (fast heat balance not enabled and external device not be controlled)	BASE: Typ. 1.5 W @ 12 VDC PRO: Typ. 1.6 W @ 12 VDC (fast heat balance not enabled) MAX: Typ. 1.7 W @ 24 VDC (fast heat balance not enabled and external device not be controlled)

Mechanical	
Lens mount	C-mount
Dimension	BASE + PRO: 29 mm × 29 mm × 42 mm (1.1" × 1.1" × 1.7") MAX: 42 mm × 42 mm × 43 mm (1.7" × 1.7" × 1.7")
Weight	BASE: Approx. 116 g (0.3 lb.) PRO: Approx. 124 g (0.3 lb.) MAX: Approx. 120 g (0.3 lb.)
Ingress protection	BASE: IP40 (under proper lens installation and wiring) PRO + MAX: IP67 (under proper lens and lens cap installation and wiring)
Temperature	Working temperature: -30 °C to 60 °C (-22 °F to 140 °F) Storage temperature: -30 °C to 80 °C (-22 °F to 176 °F)
Humidity	20% RH to 95% RH (no condensation)
General	
Client software	MVS or third-party software meeting with GigE Vision Protocol
Operating system	32/64-bit Windows 7/10, 64-bit Windows 11, 32/64-bit Linux
Compatibility	GigE Vision V2.0, GenICam
Certification	CE, RoHS, KC

Dimension

BASE

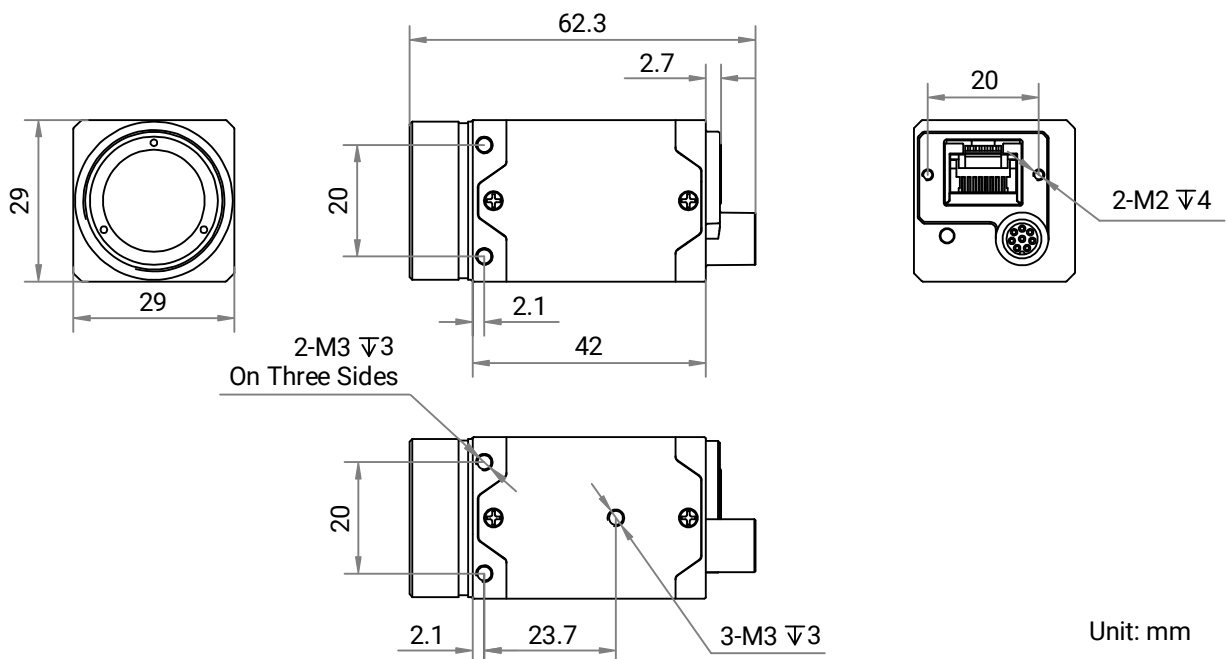

Dimension

PRO

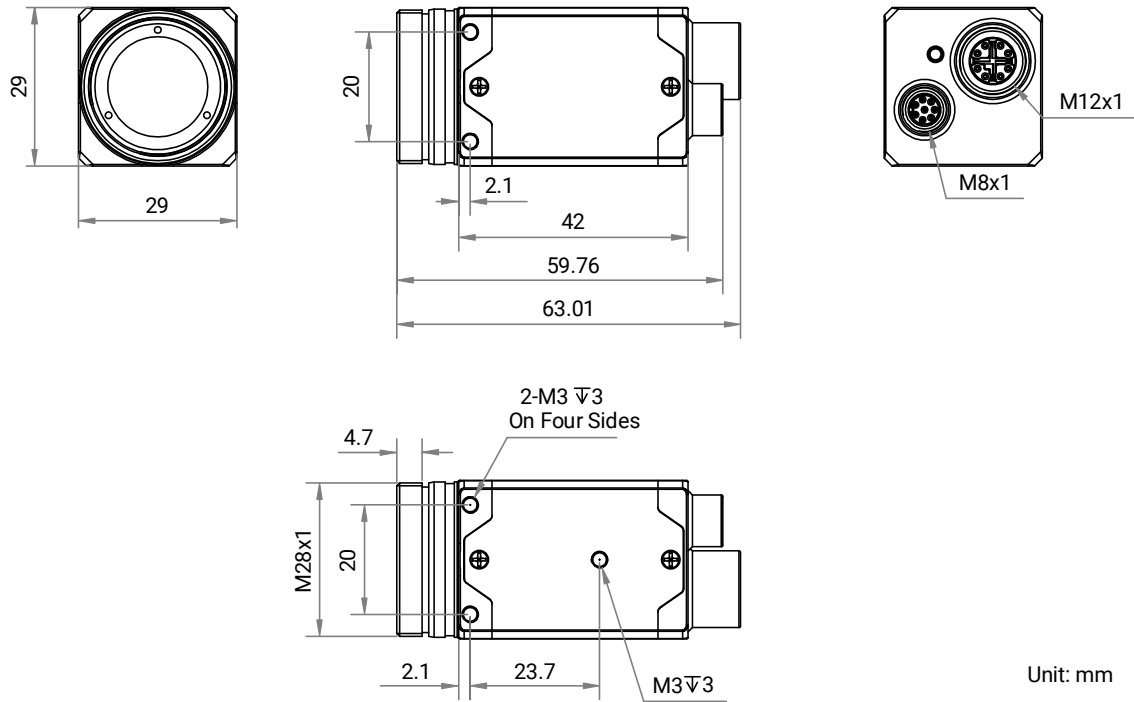

MAX

