

MV-CL082-91F2M

8192 P XoF Mono Line Scan Camera

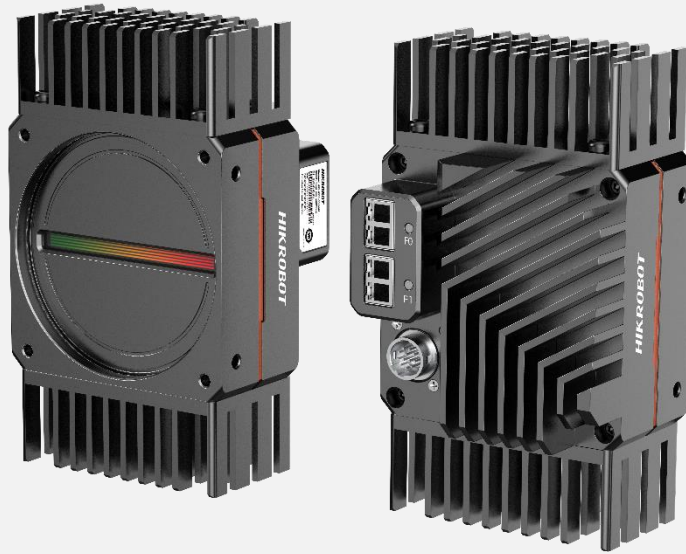

Introduction

MV-CL082-91F2M camera adopts CMOS sensor and supports transmission over its 20G fiber port, and its max. line rate reaches 200 kHz. It adopts multiple ISP image processing technologies, and is featured with high speed, high accuracy, and high performance.

Key Feature

- Adopts multiple ISP like Gamma, flat field correction, LUT, black level offset, etc.
- Provides 20G fiber port to transmit data.
- Supports multiple exposure and acquisition methods.
- Supports 2-TDI with max. line rate of 200 kHz.
- Adopts bi-directional configurable I/O hardware design.
- Compact design and flexible installation.

Dimension

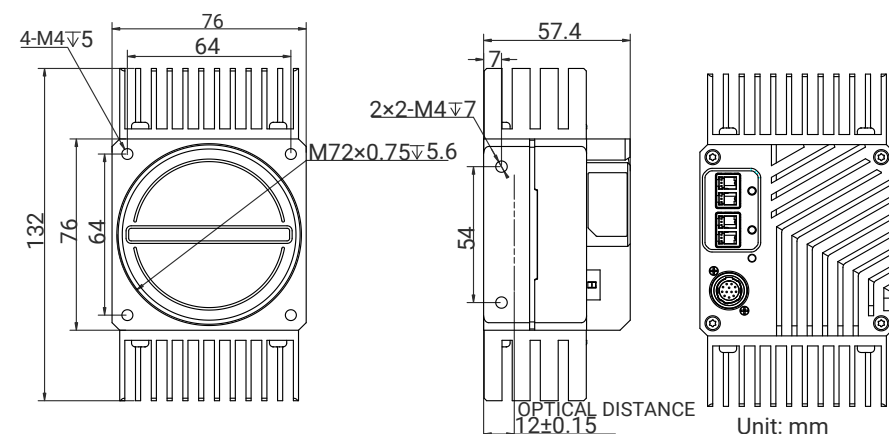

Available Model

MV-CL082-91F2M

Applicable Industry

New energy, screen detection, consumer electronics, PCB, etc.

Sensor Quantum Efficiency

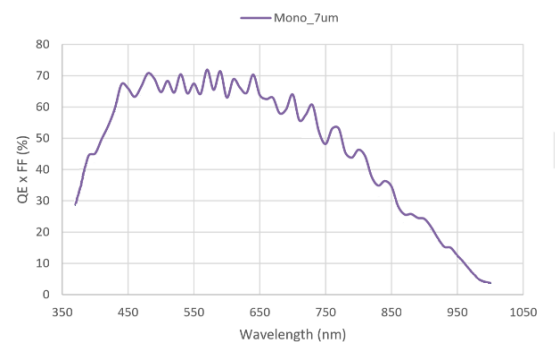

Accessories

- Frame Grabber: MV-GS1002F
- SFP+ Module: MV-AC10G-SFP
- Fiber Patch Cable: MV-AC10G-2LC-2LC-ST

Specification

Model	MV-CL082-91F2M
Performance	
Sensor type	CMOS
Pixel size	7 μm \times 7 μm
Resolution	8192 \times 2
Image mode	Supports 1-line, 2-TDI
Max. line rate	200 kHz @ Mono 8 189.4 kHz @ Mono 10 157.8 @ Mono 12
Transmission mode	1 Link, 2 Link
Dynamic range	63.4 dB
SNR	40.8 dB
Gain	Supports 1.0 \times
Exposure time	3 μs to 10 ms
Exposure mode	Off/ Once/ Continuous exposure mode, and supports trigger-width exposure
Mono/color	Mono
Pixel format	Mono 8/10/12
Binning	Supports 1 \times 1, 1 \times 2, 1 \times 4, 2 \times 1, 2 \times 2, 2 \times 4, 4 \times 1, 4 \times 2, 4 \times 4
Reverse image	Supports horizontal reverse image output
Trigger mode	External trigger, internal trigger
External trigger mode	Line trigger, frame trigger, line + frame trigger
Electrical feature	
Data interface	2LC fiber connector
Digital I/O	12-pin P10 connector provides power and I/O: Configurable input/output \times 4 (Line 0/1/3/4) and single-ended/differential is supported.
Power supply	12 VDC to 24 VDC
Power consumption	Typ. 14 W@24 VDC
Mechanical	
Lens mount	M72 *0.75, optical back focal length: 12 mm (0.5"), applicable to F-mount via lens adapter
Dimension	132 mm \times 76 mm \times 57.4 mm (5.2" \times 3.0" \times 2.3")
Weight	Approx. 600 g (1.3 lb.)
Ingress protection	IP40 (under proper lens installation and wiring)
Temperature	Working temperature: -20 $^{\circ}\text{C}$ to 50 $^{\circ}\text{C}$ (-4 $^{\circ}\text{F}$ to 122 $^{\circ}\text{F}$) Storage temperature: -30 $^{\circ}\text{C}$ to 80 $^{\circ}\text{C}$ (-22 $^{\circ}\text{F}$ to 176 $^{\circ}\text{F}$)
Humidity	5% to 90% RH, non-condensing
General	
Client software	MVS
Operating system	32/64-bit Windows XP/7/10
Compatibility	Self-developed protocol, GenICam
Certification	CE, RoHS, KC