

## MV-CH310-10XM-F-NF

31 MP CMOS CoaXPress Area Scan Camera

### Introduction

MV-CH310-10XM-F-NF camera adopts Sony IMX 342 sensor and provides high quality image. It transmits data via CXP-6 interface. With high dynamic range and high signal-noise ratio, it is widely applied to PCB AOI, FPD, high-accuracy measurement, and etc.



GEN*i*CAM CoaXPress®

### Key Feature

- Resolution 6464 × 4852, and pixel size 3.45 μm × 3.45 μm
- Adopts CMOS global shutter to provide high dynamic range, SNR and high quality image
- Adopts CXP-6 interface to transmit data
- Compatible with CoaXPress Protocol, and GenICam standard

### Applicable Industry

PCB AOI, FPD, high-accuracy measurement, railway related application, and etc.

### Sensor Quantum Efficiency

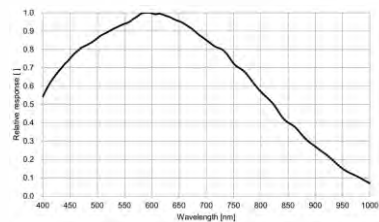

### Available Model

MV-CH310-10XM-F-NF

MV-CH310-10XM-F-NF

### Dimension

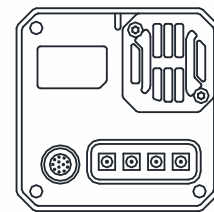
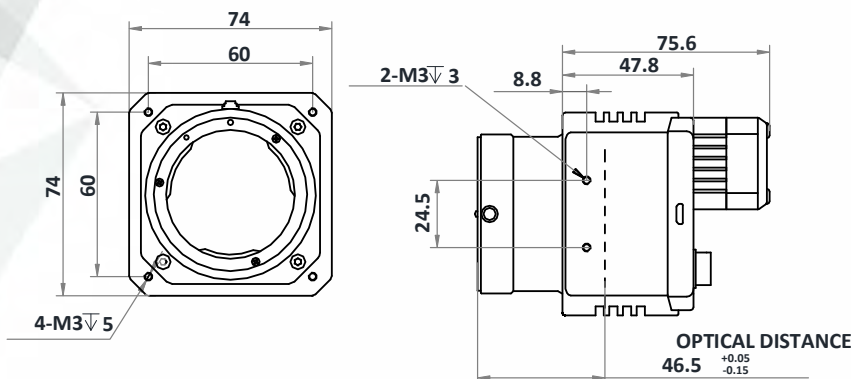

Unit: mm



## Specification

Model	MV-CH310-10XM-F-NF
Parameters	31 MP CMOS CoaXPress Area Scan Camera
<b>Camera</b>	
Sensor type	CMOS, global shutter
Sensor model	Sony IMX 342
Pixel size	3.45 $\mu\text{m}$ $\times$ 3.45 $\mu\text{m}$
Sensor size	APS-C
Resolution	6464 $\times$ 4852
Frame rate	ADC 8bit mode: 17.9 fps; ADC 12bit mode: 12.1 fps
Mono/color	Mono
Pixel format	ADC 8bit mode: Mono 8; ADC 12bit mode: Mono 8 / 10/ 12
Dynamic range	73 dB
SNR	40 dB
Gain	0 dB to 20 dB
Exposure time	UltraShort exposure mode: 3 $\mu\text{s}$ to 33 $\mu\text{s}$
	ADC 8bit mode: 47 $\mu\text{s}$ to 2 s
	ADC 12bit mode: 36 $\mu\text{s}$ to 2 s
Shutter mode	Off/ Once /Continuous exposure mode
Acquisition mode	Continuous mode, single frame mode
Reverse image	Supports horizontal and vertical reverse image output
<b>Electrical features</b>	
Data interface	CoaXPress (DIN interface)
Digital I/O	12-pin I/O interface; opto-isolated input x1 (Line 0), opto-isolated output x1 (Line 1), bi-directional non-isolated I/O x 1 (Line 2), RS-232 x1, and RS-485 interface x 1
Power supply	9 VDC to 26 VDC
Power consumption	< 9.1 W@12 VDC
<b>Structure</b>	
Lens mount	F-Mount, optical back focal length 46.5 mm (1.8")
Dimension	74 mm $\times$ 74 mm $\times$ 75.6 mm (2.9" $\times$ 2.9" $\times$ 3.0")
Weight	Approx. 650 g (1.4 lb.)
Ingress protection	IP 40 (under proper lens installation and wiring)
Temperature	Working temperature: 0 $^{\circ}\text{C}$ to 50 $^{\circ}\text{C}$ (32 $^{\circ}\text{F}$ to 122 $^{\circ}\text{F}$ )
	Storage temperature: -30 $^{\circ}\text{C}$ to 70 $^{\circ}\text{C}$ (-22 $^{\circ}\text{F}$ to 158 $^{\circ}\text{F}$ )
Humidity	20% to 95% RH, without condensation
<b>General</b>	
Client software	Frame grabber software meeting with CoaXPress Protocol
Operating system	Windows 7/10 32/64-bit
Compatibility	CoaXPress, GenICam
Certification	CE, FCC, RoHS