



BI-TELECENTRIC LENS FOR 2/3" TO 1/4" MATRIX DETECTORS

Model:	TC 23 64		
Magnification (X):	0.14		
Object Field (mm):	1/4" (3,6 x 2,7):	26.2	x 19.6
	1/3" (4,8 x 3,6):	34.9	x 26.2
	1/2" (6,4 x 4,8):	46.5	x 34.9
	1/1.8" (7,13 x 5,37):	51.8	x 39.0
	2/3" (8,8 x 6,6):	64.0	x 48.0
Working Distance (mm):	182.3 +/- 5		
Working F-number:	8		
MTF @70 lp/mm (%):	>50		
Field Depth (mm):	36.0 @ F/ 8		
Image side N.A.:	0.062		
Object side N.A.:	0.009		
Telecentricity (degree):	<0,08		
Distortion (%):	<0,07		
Mount:	C		
Length (mm):	246		
Maximum external diameter (mm):	100		
Weigh (g):	1100		

NOTES:

- 1) The inner aperture diaphragm can be supplied on request with smaller apertures in order to achieve a larger Field Depth
- 2) Compatible with LT RN 64 diffusive ring light
- 3) Specific "Teleclamp64" mechanical interface available
- 4) Can be coupled to a collimated light illuminator like LT CL 64
- 5) Compatible with Diffuse Coaxial LT CX 64 Illuminator

Rev No.	Description	Date	Name
A	First light	01/05/03	A.Vismara
D	Redesign	15/02/06	A.Vismara

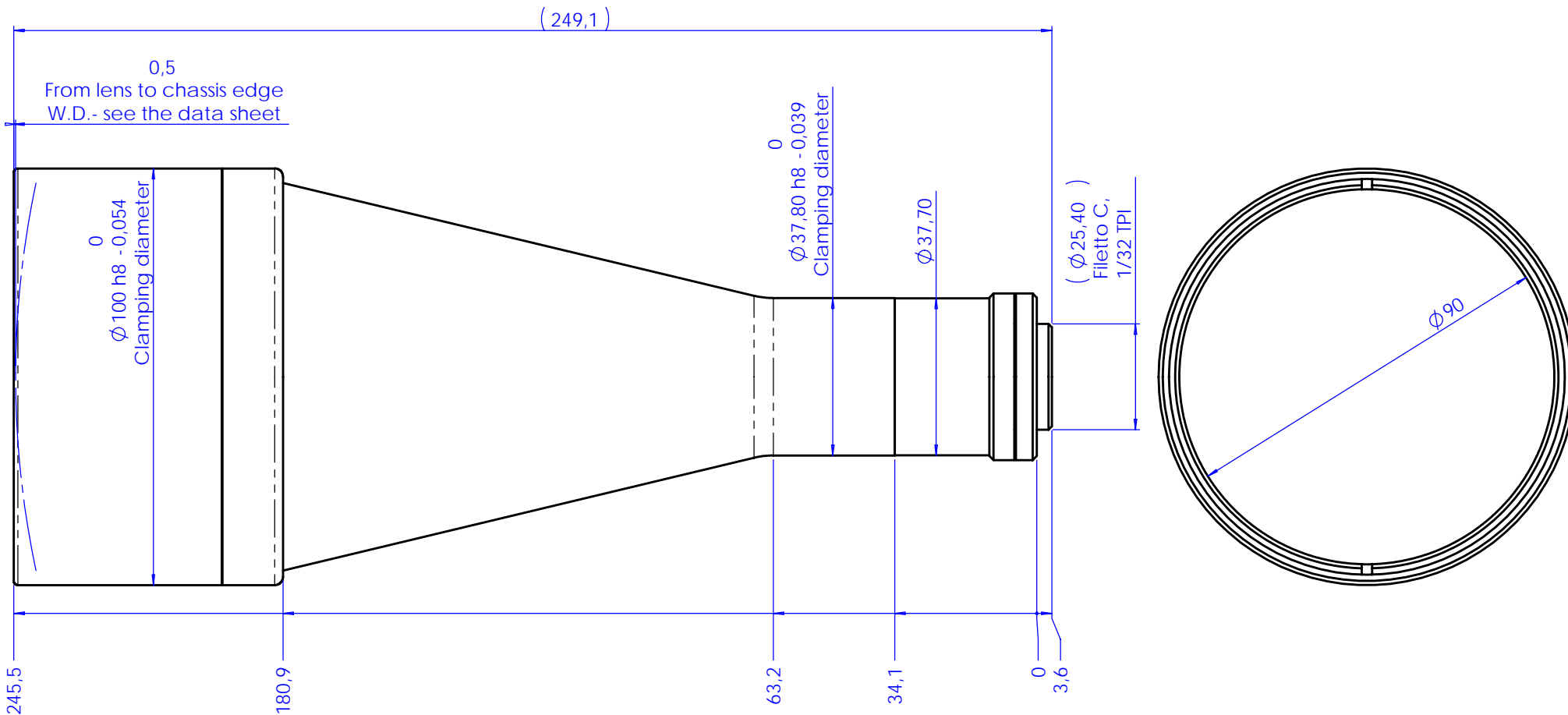

Material	N.A.			Mass	1.1 kg	Scale	1:1
Surface treatment	N.A.			Project-Prod.Item/Instrument Telecentric lens 23 64			
Geometrical tolerance (ISO 2768-2)			Class	K	Description		
Linear tolerance (ISO 2768-2)			Class	m	Undimensioned bevels	1x45°	Assembly
0.5	>3-	>6-	>30+	>120	>400+	>1000	
+3	6	30	120	+400	1000	+2000	R 0.5
±0.1	±0.1	±0.2	±0.3	±0.5	±0.8	±1.2	±2
www.opto-engineering.com			Date	Name	Drawing No.		
			Designed	15/02/06	A.Vismara	01401-0-D	
			Draw	15/02/06	A.Vismara	Sheet	
			Checked	X	C. Sedazzari	1/1	
OPTO ENGINEERING S.r.l. - 46100 Mantova Italy - Via Cremona, 28 - Tel. +39 0376 229585 - e-mail: info@opto-engineering.com - http://www.opto-engineering.com							