

WWW.OPTO-ENGINEERING.COM

## BI-TELECENTRIC LENS FOR 2/3" TO 1/4" MATRIX DETECTORS

<b>Model:</b>	<b>TC 23 36</b>		
<b>Magnification (X):</b>	0.24		
<b>Object Field (mm):</b>	1/4" (3,6 x 2,7):	14.7	x 11.0
	1/3" (4,8 x 3,6):	19.6	x 14.7
	1/2" (6,4 x 4,8):	26.2	x 19.6
	1/1.8" (7,13 x 5,37):	29.2	x 22.0
	2/3" (8,8 x 6,6):	36.0	x 27.0
<b>Working Distance (mm):</b>	103.5 +/- 3		
<b>Working F-number:</b>	8		
<b>MTF @70 lp/mm (%):</b>	>40		
<b>Field Depth (mm):</b>	12.0	@	F/ 8
<b>Image side N.A.:</b>	0.062		
<b>Object side N.A.:</b>	0.015		
<b>Telecentricity (degree):</b>	<0,08		
<b>Distortion (%):</b>	< 0,10		
<b>Mount:</b>	C		
<b>Length (mm):</b>	165		
<b>Maximum external diameter (mm):</b>	61		
<b>Weigh (g):</b>	520		

### NOTES:

- 1) The inner aperture diaphragm can be supplied on request with smaller apertures in order to achieve a larger Field Depth
- 2) Compatible with LT RN 36 diffusive ring light
- 3) Specific "Teleclamp36" mechanical interface available
- 4) Can be coupled to a collimated light illuminator like LT CL 36
- 5) Compatible with Diffuse Coaxial LT CX 36 Illuminator

Rev No.	Description	Date	Name
A	First light	01/05/03	A.Vismara
D	Redesign	15/02/06	A.Vismara

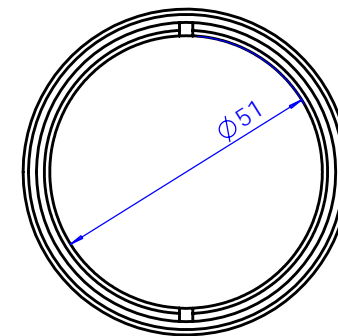
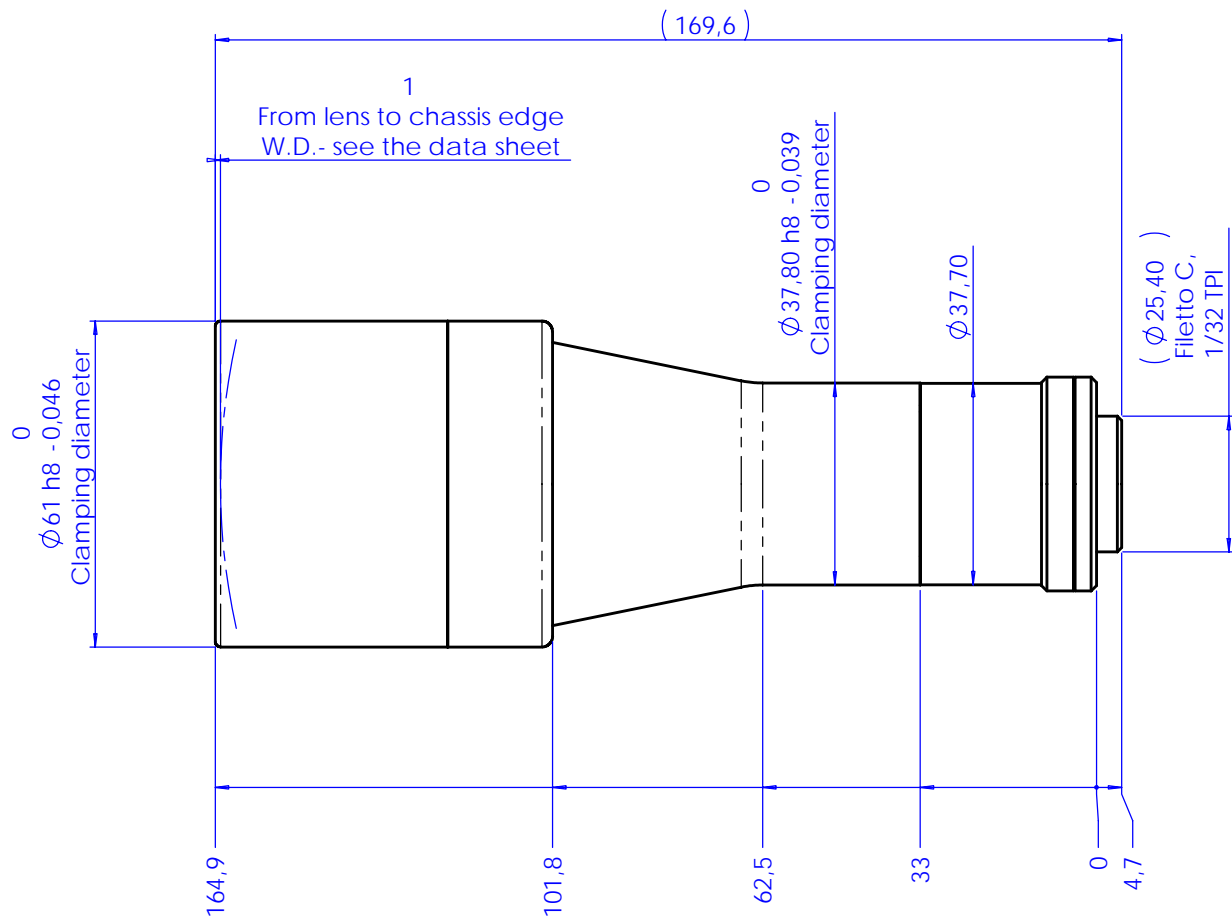

Material	N.A.			Mass	0.52 kg	Scale	1:1
Surface treatment	N.A.			Project-Prod.Item/Instrument Telecentric lens 23 36			
Geometrical tolerance (ISO 2768-2)			Class	K	Description		
Linear tolerance (ISO 2768-2)			Class	m	Undimensioned bevels	1x45°	Assembly
0.5	>3-	>6-	>30-	>120	>400-	>1000	
+3	6	30	120	+400	1000	+2000	R 0.5
±0.1	±0.1	±0.2	±0.3	±0.5	±0.8	±1.2	±2
www.opto-engineering.com			Date	Name		Drawing No.	
			Designed	15/02/06	A.Vismara	01201-0-D	
			Draw	15/02/06	A.Vismara	Sheet	
			Checked	X	C. Sedazzari	1/1	
Reproduction forbidden without specific authorization							