

## FCB-EX Series

Sony introduces a new line of Colour Block Cameras to the FCB-EX Series, each of which incorporates advanced Digital Signal Processing (DSP) and a 1/4-type EXview HAD CCD™.

## INTRODUCTION

This combination enables these cameras to reproduce extremely high horizontal resolution of 530 TV lines and provides amazingly clear and detailed images. The new line of block cameras joining the FCB-EX Series offers the choice of a 36x, 26x and 18x zoom lens, allowing users to select a camera model that meets their specific monitoring application requirements.

Also, these cameras are equipped with a Wide Dynamic Range function that dramatically improves the camera dynamic range by 128x when compared to conventional cameras, reproducing high-contrast images of the original scene. In addition, an advanced slow AE response function provides clear images even when monitoring areas where the lighting conditions change abruptly, making these cameras suitable for use in a variety of applications.

What's more, these cameras are equipped with a number of convenient new functions such as Spherical Privacy Zone Masking with Mosaic Effect, Video Motion Detection and Multi-Line On-Screen Display, as well as features inherited from earlier FCB-EX Series cameras such as e-Flip, Picture Freeze and Auto ICR.

Producing extremely clear and detailed images and incorporating a variety of convenient features, these FCB-EX Series colour block cameras are the perfect choice for monitoring applications that demand high performance. Whether your requirement is for a fixed, dome, or Pan/Tilt/Zoom camera, in demanding indoor or outdoor security and traffic-monitoring applications, the FCB-EX Series is the ideal solution.



## COLOUR BLOCK CAMERAS

### FCB-EX Series

FCB-EX1010/EX1010P

FCB-EX990D/EX990DP

FCB-EX490D/EX490DP

[www.sonybiz.net/vision](http://www.sonybiz.net/vision)



# FCB-EX SERIES LINE-UP

## FCB-EX1010/FCB-EX1010P

- > 1/4-type EXview HAD CCD
- > High Horizontal Resolution of 530 TV Lines
- > 432x Zoom Ratio (36x optical, 12x digital)
- > Wide Dynamic Range
- > Advanced Spherical Privacy Zone Masking Function with Mosaic Effect
- > Video Motion Detection
- > Minimum Illumination of 1.4 lx (typical) at 1/60 s shutter speed and 0.1 lx (typical) at 1/4 s shutter speed
- > Multi-Line On-Screen Display
- > e-Flip Function
- > Auto ICR (IR-cut filter Removal) Mode
- > Picture Freeze Function
- > Key Switch Connector (CN702) for Camera Control with External Equipment
- > Electronic Shutter/Slow Shutter
- > High-Speed Serial Interface (maximum 38.4 Kb/s) with TTL Signal-Level Control (VISCA protocol)
- > Internal/External Sync

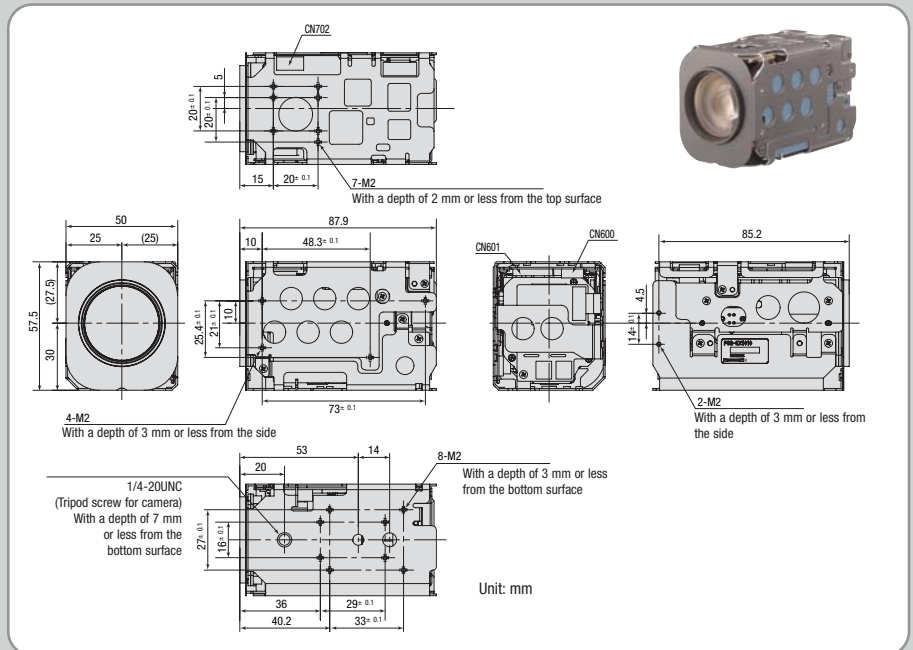

## FCB-EX990D/FCB-EX990DP

- > 1/4-type EXview HAD CCD
- > High Horizontal Resolution of 530 TV Lines
- > 312x Zoom Ratio (26x optical, 12x digital)
- > Wide Dynamic Range
- > Advanced Spherical Privacy Zone Masking Function with Mosaic Effect
- > Video Motion Detection
- > Minimum Illumination of 1.0 lx (typical) at 1/60 s shutter speed and 0.09 lx (typical) at 1/4 s shutter speed
- > Multi-Line On-Screen Display
- > e-Flip Function
- > Auto ICR (IR-cut filter Removal) Mode
- > Picture Freeze Function
- > Key Switch Connector (CN501) for Camera Control with External Equipment
- > Electronic Shutter/Slow Shutter
- > High-Speed Serial Interface (maximum 38.4 Kb/s) with TTL Signal-Level Control (VISCA protocol)
- > Internal/External Sync

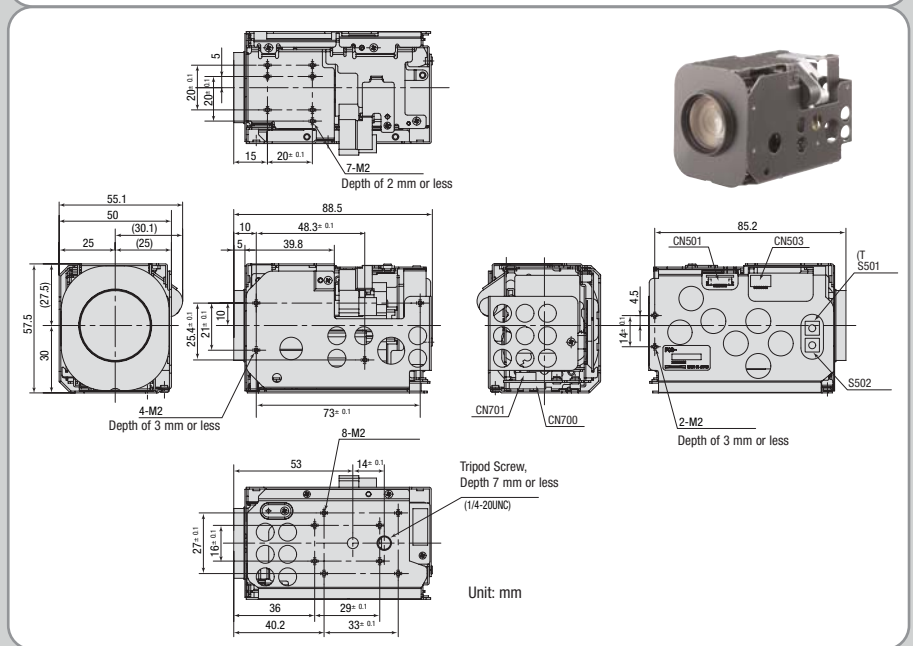

## FCB-EX490D/FCB-EX490DP

- > 1/4-type EXview HAD CCD
- > High Horizontal Resolution of 530 TV Lines
- > 216x Zoom Ratio (18x optical, 12x digital)
- > Wide Dynamic Range
- > Advanced Spherical Privacy Zone Masking Function
- > Video Motion Detection
- > Minimum Illumination of 0.7 lx (typical) at 1/60 s shutter speed and 0.07 lx (typical) at 1/4 s shutter speed
- > Multi-Line On-Screen Display
- > e-Flip Function
- > Auto ICR (IR-cut filter Removal) Mode
- > Picture Freeze Function
- > Key Switch Connector (CN501) for Camera Control with External Equipment
- > Electronic Shutter/Slow Shutter
- > High-Speed Serial Interface (maximum 38.4 Kb/s) with TTL Signal-Level Control (VISCA protocol)
- > Internal/External Sync

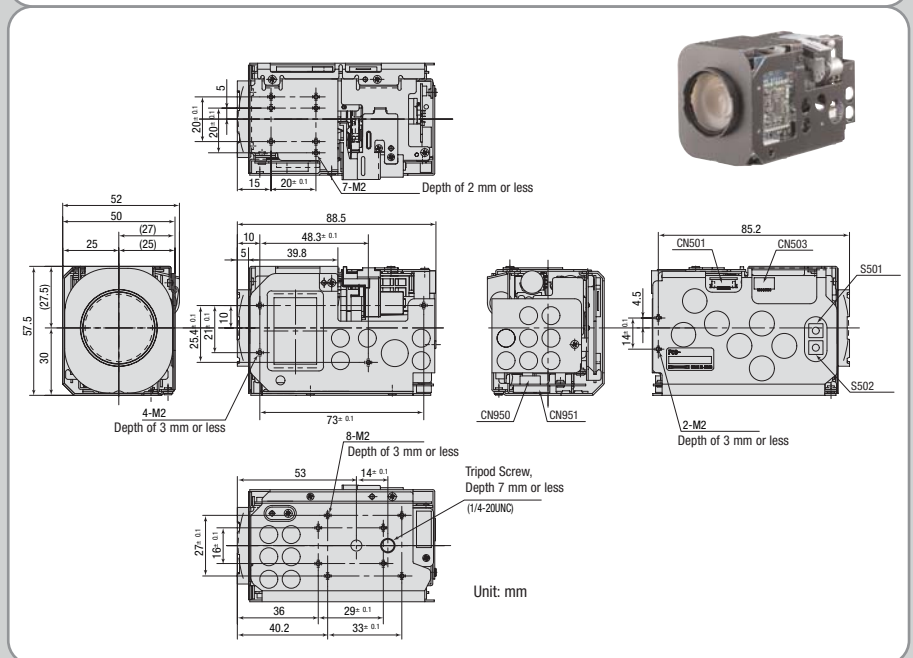

# FEATURES

## • Wide Dynamic Range

The FCB-EX Series of cameras incorporate an advanced backlight compensation technology that dramatically improves camera dynamic range by 128 times when compared to conventional cameras, resulting in clear image reproduction in extreme high-contrast environments. These cameras capture the same image twice – first with a normal shutter speed and then with a high shutter speed. The dark areas captured at normal shutter speed and the bright areas captured at high shutter speed are then combined into one image using an advanced DSP LSI, thus clearly reproducing the original scene.

## • High-Resolution Images

Combining a newly developed DSP with a 1/4-type EXview HAD CCD, these cameras achieve high horizontal resolution of 530 TV lines, enabling reproduction of amazingly clear and detailed images.

## • Slow AE Response Function<sup>1</sup>

These cameras are equipped with a Slow AE response function to automatically slow the rate at which camera exposure levels change. The rate can be set up to 32 times slower than when Full-Auto AE or Priority (shutter/iris) modes are selected<sup>2</sup>. This function is useful when monitoring areas in which lighting conditions change abruptly. For example, if the camera is used to monitor the flow of nighttime traffic when vehicle headlights are pointed directly towards it, the camera's exposure level is reduced slowly. This can allow users to monitor and identify crucial parts of the image that surround the headlights, such as a car's license plate or a driver's face.

1 This function can be set using VISCA™ protocol.

2 The rate at which camera exposure levels are adjusted when in Full-Auto AE or Priority modes is just under one second.

## • Powerful and Versatile Zoom Capability/ Wide Viewing Angle

The FCB-EX1010/EX1010P cameras incorporate a powerful 36x optical zoom lens, allowing for a zoom capability of up to 432x when used in combination with its 12x digital zoom. The FCB-EX990D/EX990DP cameras incorporate a 26x optical zoom lens and the FCB-EX490D/EX490DP cameras incorporate an 18x optical zoom lens. Users can choose a camera that has the appropriate zoom ratio for their specific application requirements. Also, the FCB-EX1010/EX1010P features a wide viewing angle of 57.8° to 1.7° making it ideal for use in security dome cameras.

## • Video Motion Detection

These cameras incorporate a video motion detection function. When motion is detected within an area of the picture designated by the user, an alarm signal is output via the camera's control interface using the VISCA™ protocol. Users can designate up to four detecting areas freely from any of 8 vertical and 12 horizontal blocks.

## • Multi-Line On-Screen Display

Up to eleven lines with 20 characters per line can be displayed on the monitoring screen using VISCA commands. Users can freely display captions on the screen such as monitoring location, camera name and alarm messages, providing operators with a user-friendly interface.

## • Electronic-Flip (e-Flip)

These cameras have an e-Flip function that electronically flips an image upside down so that it is displayed on the monitor accurately. In a dome application for example, if a tracked object moves beneath the camera dome, the image is inverted to maintain the correct orientation.

## • SMART (Sony Modular Automatic Lens Reset Technology) Lens Control

These cameras incorporate SMART Lens Control technology that monitors the focus position of the lens during zooming and automatically compensates for any mechanical misalignment that may occur over long periods of continuous usage. With the introduction of SMART Lens Control, periodic lens initialisation is no longer required during continuous 24-hour operation.

## • Auto IR-Cut Filter Removal (ICR)

For optimised sensitivity in both day and night shooting applications, these cameras incorporate an Auto ICR function. At a set level of darkness, the IR-cut filter is automatically disabled (ICR ON) and the infrared sensitivity is increased. At a set level of brightness, the filter is automatically enabled (ICR OFF). The IR-cut filter automatically engages depending on the ambient light, allowing the camera to be effective in a variety of lighting conditions.

## • Picture Freeze

The FCB-EX Series of cameras are equipped with a Picture Freeze function that allows for the output of a still image while the camera is panning, tilting, zooming, focusing, initialising the lens, or performing preset operations. For example, the camera will output a still image before it begins to pan, tilt, or zoom. Once the operation is completed, the camera continues to display images that are currently being monitored; in this way, unnecessary images are not displayed.

### Wide Dynamic Range



At normal speed shutter

At high speed shutter



FCB-EX D Version camera image

Simulated images

### Spherical Privacy Zone Masking

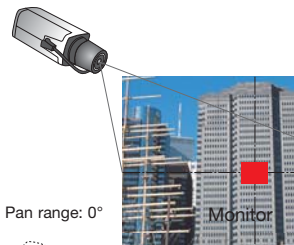

Pan range: 0°

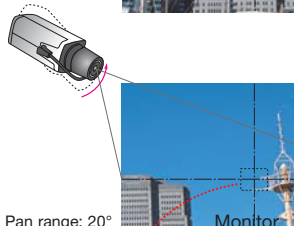

Pan range: 20°

■ Masking area  
- - - Movement of masking area

### Multi-Line On-Screen Display



# SPECIFICATIONS

	FCB-EX1010	FCB-EX1010P	FCB-EX990D	FCB-EX990DP	FCB-EX490D	FCB-EX490DP
Image device	1/4-type EXview HAD CCD					
Effective picture elements (Approx.)	380,000 pixels	440,000 pixels	380,000 pixels	440,000 pixels	380,000 pixels	440,000 pixels
Horizontal resolution	High Resolution On/Off (On: 530 TV lines)					
Lens	36x optical zoom, f=3.4 mm (wide) to 122.4 mm (tele), F1.6 to F4.5		26x optical zoom, f=3.5 mm (wide) to 91.0 mm (tele), F1.6 to F3.8		18x optical zoom, f=4.1 mm (wide) to 73.8 mm (tele), F1.4 to F3.0	
Digital zoom	12x (432x with optical zoom)		12x (312x with optical zoom)		12x (216x with optical zoom)	
Viewing angle (H)	57.8° (wide) to 1.7° (tele)		54.2° (wide) to 2.2° (tele)		48.0° (wide) to 2.8° (tele)	
Minimum object distance	320 mm (wide), 1500 mm (tele)				290 mm (wide), 800 mm (tele)	
Sync system	Internal/External (V-Lock)					
Minimum illumination	1/60 s mode: 1.4 lx (typical) (F1.6, 50IRE) 1/4 s mode: 0.1 lx (typical) (F1.6, 50IRE)		1/60 s mode: 1.0 lx (typical) (F1.6, 50IRE) 1/4 s mode: 0.09 lx (typical) (F1.6, 50IRE)		1/60 s mode: 0.7 lx (typical) (F1.4, 50IRE) 1/4 s mode: 0.07 lx (typical) (F1.4, 50IRE)	
S/N ratio	More than 50 dB (weight ON)					
Electronic shutter	1/4 to 1/10,000 s, 22 steps					
White balance	Auto, ATW, Indoor, Outdoor, One-push, Manual					
Gain	Auto / Manual (-3 to 28 dB, 2 dB steps)					
AE control	Auto, Manual, Priority mode (shutter priority & iris priority), Bright, EV compensation, Backlight compensation, Slow AE					
Wide dynamic range	On/Off					
Backlight compensation	On/Off					
Privacy zone masking	On/Off (8 masks per view/24 masks presets in the entire viewing range when integrated into a PTZ camera – 14 colours, mosaic)					
Character generator	Mode display/Multi-line OSD (OSD has priority over Mode display)					
Flicker Cancel	Auto	—	Auto	—	Auto	—
Focusing system	Auto (Sensitivity: normal, low), One-push AF, Manual, Infinity, Interval AF, Zoom Trigger AF					
Picture effects	e-Flip, Nega Art, Black & White, Mirror Image					
Zoom switch	TELE, WIDE					
Video output	VBS: 1.0 Vp-p (sync negative), Y/C					
Camera control interface	VISCA (TTL signal level), baud rate: 9.6 Kb/s, 19.2 Kb/s, 38.4 Kb/s, 1 or 2 stop-bit selectable					
Storage temperature	-20 to 60 °C (-4 to 140 °F)					
Operating temperature	0 to 50 °C (32 to 122 °F)					
Power requirements	6 to 12 V DC					
Power consumption	2.6 W (motors inactive), 4.9 W (motors active)		2.6 W (motors inactive), 5.4 W (motors active)		2.6 W (motors inactive), 4.4 W (motors active)	
Mass	230 g (8.1 oz)					
Dimensions (WxHxD)	50.0 x 57.5 x 87.9 mm (2 x 2 3/8 x 3 1/2 inches)		55.3 x 57.5 x 88.5 mm (2 x 2 3/8 x 3 1/2 inches)		52.0 x 57.5 x 88.5 mm (2 1/8 x 2 3/8 x 3 1/2 inches)	

# PIN ASSIGNMENT

## CN600

4-pin for Y/C Video Out

PIN N°.	NAME	LEVEL
①	Y_OUT	1.0 Vp-p (75 Ω terminate) Luminance signal
②	GND (for Y signal)	—
③	C_OUT	Chrominance signal
④	GND (for C signal)	—

Connector: JST S4B-ZR-SM4A-TF (LF)

## CN601

9-pin for DC/Video Out

PIN N°.	NAME	LEVEL
①	RxD	TTL/CMOS Level Read Data
②	TxD	TTL/CMOS Level Send Data
③	GND (for RxD & TxD)	—
④	DC IN	9.0 V ±3.0 V
⑤	GND (for DC IN)	—
⑥	VBS OUT	1.0 Vp-p (75 Ω terminate)
⑦	GND (for VBS OUT)	—
⑧	V LOCK PULSE	External VD-Lock Pulse (Negative, 3.0 Vp-p 50% duty)
⑨	GND (for V LOCK PULSE)	—

Connector: KYOCERA ELCO 00 6200 509 130 000+

## CN702

FCB-EX1010  
FCB-EX1010P

## CN501

FCB-EX990D/FCB-EX990DP  
FCB-EX490D/FCB-EX490DP

12-pin for Key Switch Control

PIN N°.	NAME	LEVEL
①	GND	—
②	GND	—
③	KEY_AD0	Pull up to 3.0 V by 100 kΩ
④	KEY_AD1	Pull up to 3.0 V by 100 kΩ
⑤	KEY_AD2	Pull up to 3.0 V by 100 kΩ
⑥	KEY_AD3	Pull up to 3.0 V by 100 kΩ
⑦	KEY_AD4	Pull up to 3.0 V by 100 kΩ
⑧	KEY_AD5	Pull up to 3.0 V by 100 kΩ
⑨	KEY_AD6	Pull up to 3.0 V by 100 kΩ
⑩	KEY_AD7	Pull up to 3.0 V by 100 kΩ
⑪	NC	—
⑫	Strobe	Strobe timing pulse (0 to 3.0 V)

Connector: KYOCERA ELCO 08 6222 012 101 848+

© 2008 Sony Corporation. All rights reserved. Reproduction in whole or in part without written permission is prohibited. Design, features and specifications are subject to change without notice. All non-metric weights and measurements are approximate. Sony is a registered trademark of Sony Corporation. EXview HAD CCD and VISCA are trademarks of Sony Corporation.  
CA FCB-EX Series/GB- / /2008

# SONY®