



FCB-EX11D FCB-EX11DP

Colour Block Cameras



Features

Excellent Picture Quality – High-resolution Images

Combining a high-performance DSP with a 1/4-type EXview HAD CCD sensor, the FCB-EX11D achieves a high horizontal resolution of 530 TV lines that produces amazingly clear and detailed images.

Compact and Lightweight Design

The ultra-compact and lightweight body of the FCB-EX11D makes it ideal for space-restricted applications.

Dimensions (W x H x D): 35.9 x 40.8 x 59.2 mm
(1 1/16 x 1 5/8 x 2 3/8 inches)

Mass: 95g (3.3 Oz)

Slow AE Response Function

The FCB-EX11D is equipped with a slow AE response function to automatically slow the rate at which the camera's exposure levels change. The rate can be set up to 32 times slower than when Full-Auto AE or Priority (shutter/iris) modes are selected. This function is useful when monitoring areas in which lighting conditions abruptly change.

Advanced Spherical Privacy Zone Masking with Mosaic Effect

Unwanted or prohibited areas within an image can be masked precisely and appropriately with either a solid colour or a mosaic effect. When the FCB-EX11D is integrated into a P/T/Z camera system, this technology can keep masking areas interlocked with P/T/Z movements regardless of the camera angle.

Powerful and Versatile Zoom Capability

The FCB-EX11D camera incorporates a 10x optical zoom lens, allowing for a zoom capability of up to 120x when used in combination with its 12x digital zoom.

Multi-line On-screen Display

Up to eleven lines with 20 characters per line can be displayed on the FCB-EX11D monitoring screen using VISCATM commands. Captions can be displayed on the screen to provide operators with a user-friendly interface.

Other Features

- Video Motion Detection
- Electronic-Flip (e-Flip)
- Picture Freeze
- SMART (Sony Modular Automatic Lens Reset Technology) Lens Control
- Electronic Shutter/Slow Shutter (1 to 1/10,000 s, 22 steps)
- High-Speed Serial Interface (maximum 38.4 kb/s) with TTL Signal-Level Control (VISCA protocol)
- Customisable settings
- Internal/External Sync
- 16 Bytes of Memory (for storing data such as the product serial number and camera/system ID numbers)

Outstanding picture quality in an ultra-compact design – the FCB-EX11D and FCB-EX11DP Colour Block Cameras are ideal for integration into Mini-Dome Surveillance Cameras, Traffic Monitoring Systems and more.

The popular Sony FCB series is enhancing its line-up with the addition of two new mini colour block cameras. These cameras are specifically designed for easy integration with security and monitoring systems, videoconferencing equipment, traffic monitoring systems, police vehicles, photo booths, and low vision systems.

The Sony ultra-compact and lightweight FCB-EX11D^{*1} camera incorporates a 1/4-type EXview HAD CCDTM sensor, and can be easily integrated into space restricted environments. The FCB-EX11D is not only effective in visible light, but it is sensitive to near-infrared energy enabling the camera to operate in low-light conditions. Combining a high-performance Digital Signal Processor (DSP) with an EXview HAD CCD sensor, the camera produces an extremely high horizontal resolution of 530 TV lines and provides clear and detailed images.

The FCB-EX11D is equipped with a 10x optical zoom lens which can provide a 120x zoom ratio when combined with the digital zoom. In addition, the FCB-EX11D offers a number of other useful functions such as advanced spherical privacy zone masking with mosaic effect, video motion detection, a multi-line on-screen display, and slow AE response function.

With its excellent picture quality, compact size, and feature-rich design, the FCB-EX11D is ideal for a wide range of applications. For surveillance applications, this camera is well-suited for integration with mini speed-dome, fixed-type, and Pan/Tilt/Zoom (P/T/Z) cameras. It can also be used in low vision systems, police vehicles, and for underground inspection of oil and gas pipelines.

^{*1} Unless otherwise noted in the following text, "FCB-EX11D" refers to both the FCB-EX11D and the FCB-EX11DP.

SONY

vision like.no.other™

Pin assignment & connector

CN402 4-pin for Video Y/C Out

PIN NO.	NAME	LEVEL
1	Y_OUT	1.0 Vp-p (75 Ω terminate) Luminance signal
2	GND (for Y signal)	
3	C_OUT	Chrominance signal
4	GND (for C signal)	

Connector: JST S4B-ZR-SM4A-TF (LF)

CN401 9-pin for DC/Video Out

PIN NO.	NAME	LEVEL
1	RxD	TTL/CMOS Level Read Data
2	TxD	TTL/CMOS Level Send Data
3	GND (for Rx/D & Tx/D)	
4	DC IN	9.0 V ± 3 V
5	GND (for DC IN)	
6	VBS OUT	1.0 Vp-p (75 Ω terminate)
7	GND (for VBS OUT)	
8	V LOCK PULSE	External VD-Lock Pulse (EX.FV: Negative, 3 Vp-p 50% duty)
9	GND (VL PULSE)	

Connector: KYOCERA ELCO 00 6200 509 130 000+

Specifications

	FCB-EX11D	FCB-EX11DP
Image sensor	1/4-type EXview HAD CCD	
Signal system	NTSC	PAL
Number of total pixels	Approx. 380,000 pixels	Approx. 440,000 pixels
Lens	10x optical zoom, F1.8 to F2.9, f=4.2 mm (wide) to 42.0 mm (tele)	
Digital zoom	12x (120x with optical zoom)	
Horizontal resolution	High Resolution Mode On: 530 TV lines (default) High Resolution Mode Off: 470 TV lines (NTSC)/460 TV lines (PAL)	
Horizontal angle of view	46° (wide) to 4.6° (tele)	
Minimum object distance	200 mm (wide), 1.0 m (tele)	
Sync system	Internal/External (V-lock)	
Minimum illumination	1.0 lx (typical) (F1.8, 50 IRE)	
S/N ratio	More than 50 dB	
Electronic shutter	1 to 1/10,000 s, 22 steps	
White balance	Auto, ATW, Indoor, Outdoor, One-push, Manual	
Gain	Auto/Manual (-3 to 28 dB, 2dB steps)	
AE control	Auto, Manual, Priority mode, Bright, EV compensation, Backlight compensation, Slow AE	
EV compensation	-10.5 to 10.5 dB (1.5 dB steps)	
Backlight compensation	On/Off	
Privacy zone masking	On/Off (24 positions, 8 positions per screen) 14 colors + Mosaic	
Character generator	OSD: 11 Lines (20 characters per line), Camera Mode display: ON/OFF	
Flicker cancel	Auto	-
Focusing system	Auto (Sensitivity: normal, low), One-push AF, Manual, Infinity, Interval AF, Zoom trigger AF	
Picture effects	E-Flip, Nega Art, Black & White, Mirror Image	
Video output	VBS: 1.0 Vp-p (sync negative), Y/C	
Camera control interface	VISCA (TTL signal level), baud rate: 9.6 Kb/s, 19.2 Kb/s, 38.4 Kb/s, 1 or 2 stop bits (selectable)	
Storage temperature	-20 to 60 C° (-4 to 140 °F)	
Operating temperature	0 to 50 C° (32 to 122 °F)	
Power requirements	DC 6 to 12 V	
Power consumption	1.9 W (motors inactive), 2.8 W (motors active)	
Mass	95 g (3.3 oz)	
Dimensions (W x H x D)	35.9 mm x 40.8 mm x 59.2 mm (1 7/16 x 1 5/8 x 2 3/8 inches)	

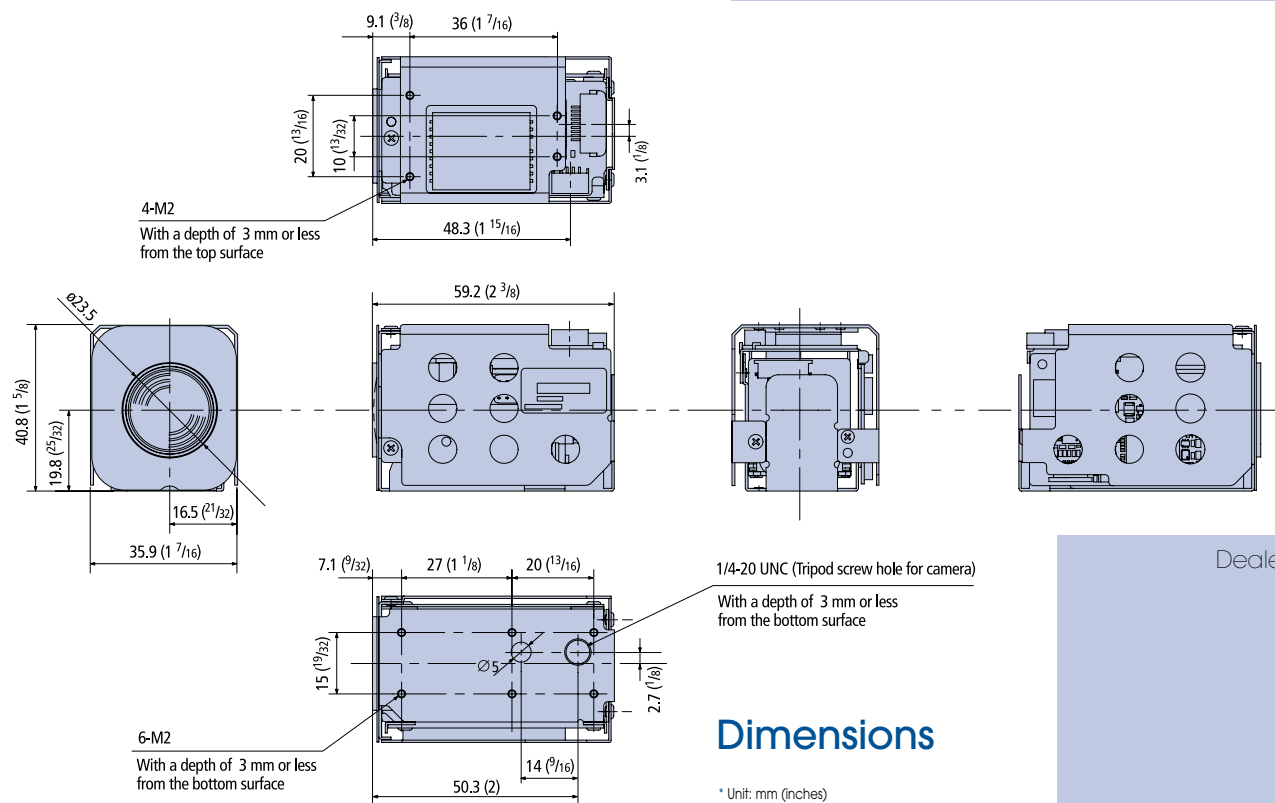

Dimensions

* Unit: mm (inches)