

EVI-HD Series

High Resolution Cameras

EVI-HD7V
EVI-HD3V
EVI-HD1



SONY

definition like.no.other™

Enhance Your Remote Presence Experience With HD

Sony, the world's leading robotic camera manufacturer, is expanding its HD Pan/Tilt/Zoom (P/T/Z) camera lineup with two new HD robotic cameras ideally suited for videoconferencing, distance learning, corporate training, and courtrooms. Whether you need standard definition, 720p, 1080i, or 1080p for your application, there is a Sony P/T/Z HD camera to capture your true-to-life images.

The all-in-one design of the EVI-HD7V and EVI-HD3V P/T/Z cameras combines Sony's expertise in HD technology with its renowned low-noise pan/tilt mechanism. The capture of intricate visual details creates the feeling of being in the same room with remote participants around the globe.

The EVI-HD7V achieves digital image acquisition of up to 1080p/60*1 for exceptional picture quality. The EVI-HD3V provides superb image quality of up to 720p/60 at an affordable price. Both cameras are equipped with a DVI-I interface, enabling easy connection to a PC monitor.

*1: 1080p/60 is only available for the EVI-HD7V.

Product lineup

EVI-HD7V



- **1080p/60**

The EVI-HD7V delivers intricately detailed and vivid images, enhancing your videoconference or training meeting with true-to-life images of the participants.

- **DVI-I Interface**

Thanks to its DVI-I interface, the EVI-HD7V is ideally suited for easy connection to a HD or PC monitor equipped with today's popular digital or analog interfaces such as DVI-D and analog component – all of which provide high-quality digital display.

EVI-HD3V



- **720p/60**

The EVI-HD3V produces stunning HD images of up to 720p/60, while offering powerful cost benefits that reduces the total system cost.

- **DVI-I Interface**

Thanks to its DVI-I interface, the EVI-HD3V is ideally suited for easy connection to a HD or PC monitor equipped with today's popular digital or analog interfaces such as DVI-D and analog component – all of which provide high-quality digital display.

EVI-HD1



- **Multi-format Video Outputs from NTSC/PAL to Full HD**

With the flip of a switch on the EVI-HD1, users can easily change between HD and SD output. This popular P/T/Z camera allows for SD to HD migration and can be used in combination with any number of codecs and other professional audio/video systems.

- **HD-SDI Interface**

The EVI-HD1 comes equipped with an HD-SDI interface that allows for long-distance transmission of HD images without degrading the picture quality. The EVI-HD1 is ideally suited for small to medium-sized conference rooms, auditoriums, and classrooms and can integrate with professional audio/video systems without the need for interface conversion.

Features

Flexibility and Choice of Video Outputs From SD to Full HD

EVI-HD Series provides multiple formats for natural and smooth video images.

	EVI-HD7V	EVI-HD3V	EVI-HD1
1080p/59.94 1080p/50	✓		
1080i/59.94 1080i/50	✓		✓
1080p/29.97 1080p/25	✓		✓
720p/59.94 720p/50	✓	✓	✓
720p/29.97 720p/25	✓	✓	✓
640 x 480p/59.94	✓ (LB)	✓ (LB)	
SD			✓ (LB,CR,SQ)

LB: Letter box CR: Cropping SQ: Squeeze

High-quality Image Transmission

The EVI-HD7V and EVI-HD3V are both equipped with a DVI-I interface that is designed to maximize high video quality of digital displays. This digital interface is capable of displaying both digital and analog signals (output is selectable from Y/Pb/Pr and RGB). The EVI-HD1 features an HD-SDI interface, enabling long-distance transmission of HD images without degrading the picture quality.

Video Interface

Camera		EVI-HD7V/HD3V	EVI-HD1
Digital output	IF	DVI-I (Digital)	HD-SDI
	Color coding	RGB or Y/Pb/Pr *1	Y/Cb/Cr
Analog output	IF	DVI-I (Analog)	Component (D-sub 15-pin)
	Color coding	RGB or Y/Pb/Pr *1	Y/Pb/Pr
	Tri-level Sync on video signal	On or Off *2	Always on
	Sync signal	HD and VD	HD and VD, or HD and Tri-level Sync *1

*1: Can be set by OSD or VISCA *2: Selected by DIP SW

Connection of EVI-HD7V/HD3V to HD Monitor

By selecting Y/Pb/Pr in color coding of EVI-HD7V/HD3V, analog component signals can be output to an HD monitor.

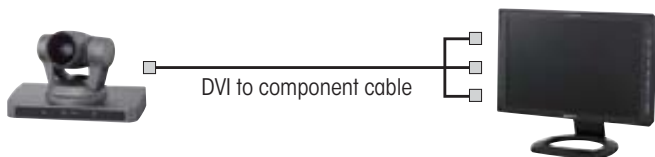

Wide-range, Quiet, and Quick Pan/Tilt Movement

All models in the EVI-HD Series utilize a direct drive motor mechanism for achieving high-speed, quiet, and smooth P/T/Z operations to capture images. These cameras cover a wide shooting range, ideal for capturing extensive areas where face-to-face discussions are critical. The face-to-face experience is enhanced by the unique quiet operation of the direct drive pan/tilt mechanism.

- Pan angle: -100° to +100°
(max pan speed: 300 degrees/s)
- Tilt angle: -25° to +25°
(max tilt speed: 125 degrees/s)

10x Optical (40x with Digital Zoom)

All models in the EVI-HD Series are equipped with a 10x optical zoom lens. They have 40x zoom ratio with 4x digital zoom lens. This fast and stable auto-focus lens can clearly capture small and intricately featured objects.

Other Features

RS-232C Remote Control (VISCA™ Protocol)

The EVI-HD Series enables camera settings and P/T/Z control functions to be performed remotely at any location and at high communication speeds via the RS-232C interface.

Six Position Presets

All models in the EVI HD Series can store up to a maximum of six preset settings for P/T/Z, focus position, exposure mode, and white balance mode.

Customizable Settings via On-screen Menu using IR Remote Commander® Unit

Users are able to adjust various camera settings using IR Remote Commander unit. The easy-to-use supplied IR Remote Commander unit is useful for full operation of the EVI-HD Series from various locations within a room.

Rear panel

EVI-HD7V/EVI-HD3V

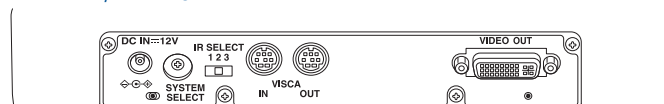

EVI-HD1

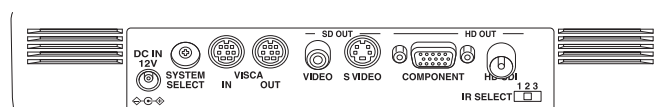

SONY

SPECIFICATIONS

	EVI-HD7V	EVI-HD3V	EVI-HD1
Image sensor	1/3-type CMOS		
Signal system	1080p/59.94, 1080p/50, 1080i/59.94, 1080i/50, 1080p/29.97, 1080p/25, 720p/59.94, 720p/50, 720p/29.97, 720p/25, 640 x 480p/59.94	720p/59.94, 720p/50, 720p/29.97, 720p/25, 640 x 480p/59.94	1080i/59.94, 1080i/50, 1080p/29.97, 1080p/25, 720p/59.94, 720p/50, 720p/29.97, 720p/25 NTSC, PAL
Lens	10x optical zoom, 40x with digital zoom, f=3.4 to 33.9 mm, F1.8 to F2.1		
Minimum object distance	100 mm (wide)		
Horizontal viewing angle	8° (tele) to 70° (wide) at HD signal output		
Focus system	Auto/Manual		
Minimum illumination	15 lx (50 IRE, F1.8)		
Exposure control	Auto* / Manual / Priority AE* / Exposure compensation / Bright		
Shutter speed	1/60 to 1/10,000 sec. (59.94 Hz system), 1/50 to 1/10,000 sec. (50 Hz system)		1/2 to 1/10,000 sec.
Gain	Auto / Manual (-3 to +18 dB)		
White balance	Auto / Indoor / Outdoor / One push auto / Manual		
Effects	—		B&W, Nega Art
S/N ratio	50 dB		
Pan/Tilt	Pan: ±100° (Max. speed 300°/sec.) Tilt: ±25° (Max. speed 125°/sec.)		
Position preset	6 positions		
Video output	DV-I (Digital and Analog)		HD: HD-SDI, Analog Component (Y/Pb/Pr) SD: VBS, Y/C
Control terminal	RS-232C (8-pin mini DIN) control (VSCA)		
Power requirements	12 V DC (10.8 to 13.0 V DC)		
Power consumption	Max. 26.4 W (at DC 12 V)		Max. 30 W (at DC 12 V)
Operating temperature	0 to 40°C (32 to 104°F)		
Storage temperature	-20 to 60°C (-4 to 140°F)		
Dimensions (W x H x D)	250 x 152 x 135 mm (9 7/8 x 6 x 5 3/8 inches) (without protrusions)		259 x 150 x 169 mm (10 1/4 x 6 x 6 3/4 inches) (without protrusions)
Mass	Approx. 1.5 kg (3 lb 5 oz)		Approx. 2 kg (4 lb 7 oz)
Supplied accessories	AC adaptor, AC power cable, IR remote commander unit, Operating instruction		

*Max gain limit is available for EVI-HD7V/HD3V.

DIMENSIONS

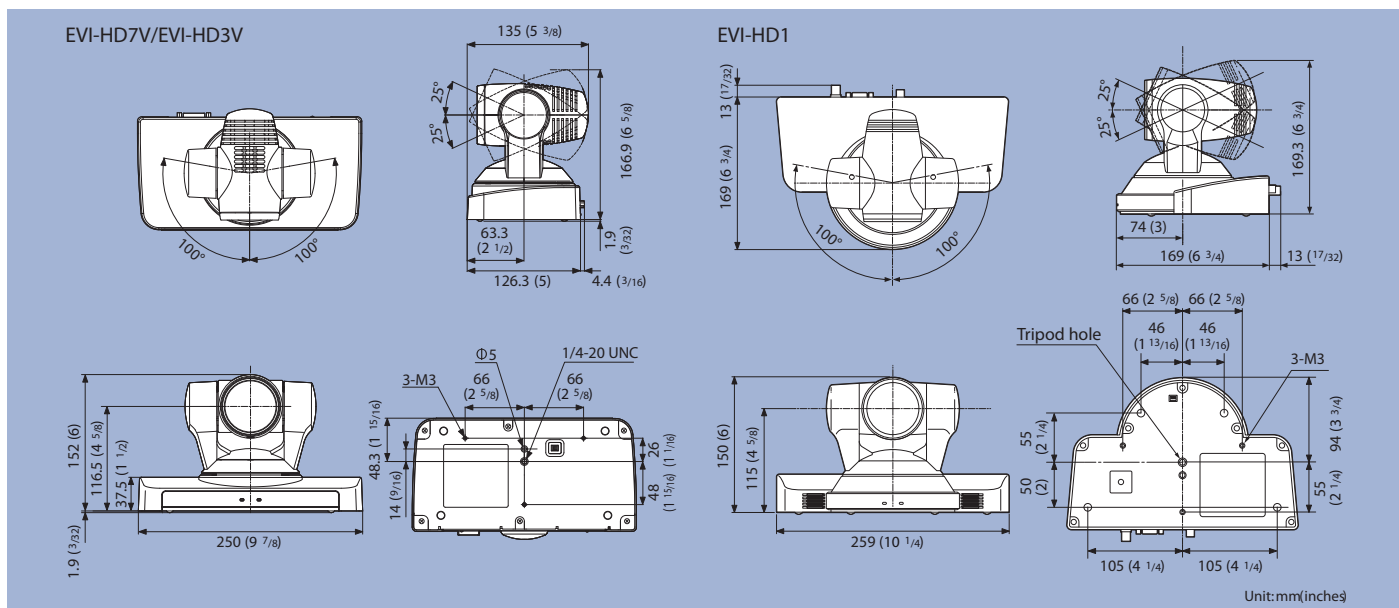

Distributed by

MaxxVision®

Sigmaringer Str. 121
70567 Stuttgart
Tel.: +49 711 997 996 3
www.maxxvision.com

SONY