



## 3D OPTICS

**LTPR Series** are the most advanced and efficient devices for Pattern Projection and Structured Light applications, such as 3D reconstruction.

Unlike Laser Sources, which typically show poor line sharpness and power distribution inhomogeneity as well as scattering and diffraction effects, LT PR overcome all of these problems by integrating LED sources and precisely engraved masks.

Any kind of pattern shape can be easily supplied, integrated and projected by these devices. Different colours, including UV and IR, are available and the size of the projection area can be easily modified by interchanging the projection optics.

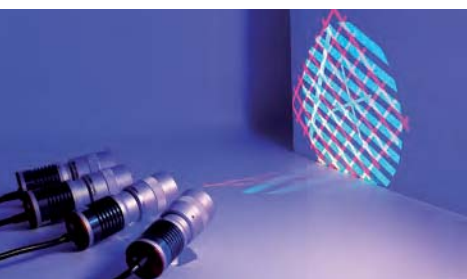

LTPR Series projectors are available in different colours.



LTPR36/UV405 projecting a cross at 405 nm.

Any shape can be projected

## LTPR SERIES

### LED pattern projectors

UV and IR  
versions available

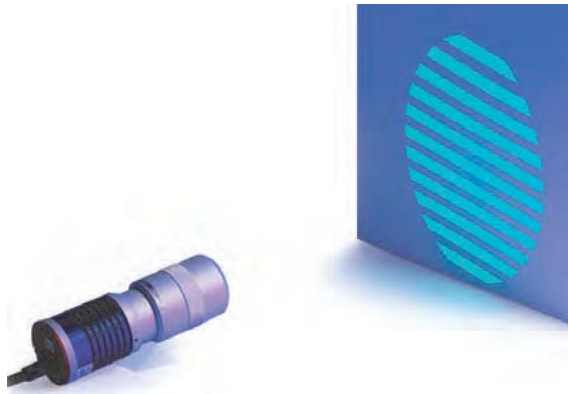

Any colour is available

part number	light color, wavelength peak
<b>1W type VIS PATTERN PROJECTORS</b>	
LTPR36/R	red, 630 nm
LTPR36/G	green, 520 nm
LTPR36/B	blue, 460 nm
LTPR36/W	white
<b>3W type VIS PATTERN PROJECTORS</b>	
LTPR3W/R	red, 630 nm
LTPR3W/G	green, 520 nm
LTPR3W/B	blue, 460 nm
LTPR3W/W	white
<b>IR PATTERN PROJECTORS</b>	
LTPR36/IR890	IR, 890 nm
LTPR36/IR940	IR, 940 nm
<b>UV PATTERN PROJECTORS</b>	
LTPR36/UV365	UV, 365 nm
LTPR36/UV385	UV, 385 nm
LTPR36/UV405	UV, 405 nm

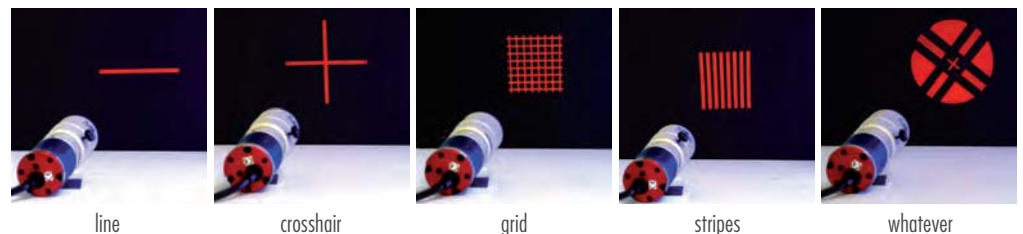

line

crosshair

grid

stripes

whatever

### Application Example



profile measurement

3D reconstruction

visualization & mapping

mechanical alignment

### KEY ADVANTAGES

Perfectly sharp edges



**LT PR SERIES** ensures thinner lines, sharper edges and more homogeneous illumination than lasers.



With **laser** emitters the illumination decays both across the line cross section and along the line width.



**Laser** emitters lines are thicker and show blurred edges; diffraction and speckle effects are also present.



## LTPR SERIES

## 3D OPTICS

### LED Typical Spectrum

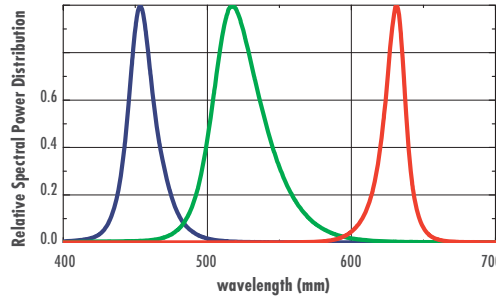
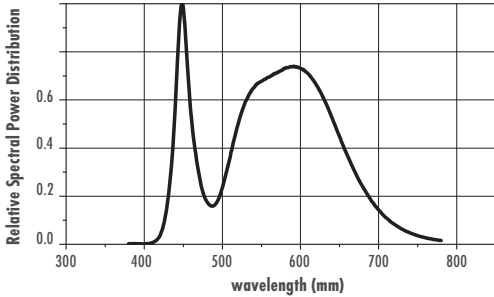

**/UVxxx and /IRxxx versions:**

peak emission wavelength: xxx nm

optical bandpass:  
+/- 20 nm FWHM

class:  
IIIb LED product

### Most optics are suitable for projection

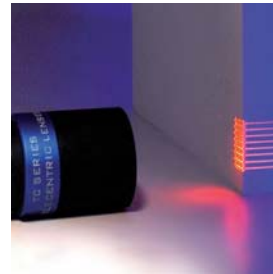

LTPR projectors can integrate specific projection optics (OEPL Series) as well most kinds of C-mount 2/3" machine vision lenses by means of the C-mount adaptor included in the package. The device can also be interfaced to microscopy systems and to telecentric lenses to as to provide telecentric pattern projection.

### Devices can be driven with flexibility



These LED devices integrate built-in switching electronics which control the current flow through the LED and which can be easily tuned by the user. This ensures both high light stability and a longer lifetime of the product.

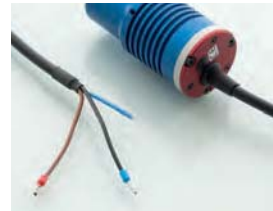

The inner circuitry can be bypassed in order to directly drive the LED. Simply connect the black and blue wires to your power supply instead of the black and brown ones, ensuring that the maximum rates are not exceeded.

part number	light color, wavelength peak	device power rating			led power rating		
		minimum DC voltage (volt)	maximum DC voltage (volt)	power consumption (watt)	forward voltage (volt)	forward current (mA)	pulse ratings @0,1 duty/1kHz (mA)
<b>1W type VIS PATTERN PROJECTORS</b>							
LTPR36/R	red, 630 nm	12	24	< 2	2,3	350	< 1800
LTPR36/G	green, 520 nm	12	24	< 2	3,5	350	< 1800
LTPR36/B	blue, 460 nm	12	24	< 2	3,5	350	< 1800
LTPR36/W	white	12	24	< 2	3,5	300	< 1800
<b>3W type VIS PATTERN PROJECTORS:</b>							
LTPR3W/R	red, 630 nm	12	24	< 3	2,6	700	< 1800
LTPR3W/G	green, 520 nm	12	24	< 3	3,8	700	< 1800
LTPR3W/B	blue, 460 nm	12	24	< 3	3,8	700	< 1800
LTPR3W/W	white	12	24	< 3	3,8	700	< 1800
<b>IR PATTERN PROJECTORS</b>							
LTPR36/IR890	IR, 890 nm	12	24	< 2	1,6	500	n.a.
LTPR36/IR940	IR, 940 nm	12	24	< 2	1,6	500	n.a.
<b>UV PATTERN PROJECTORS</b>							
LTPR36/UV365	UV, 365 nm	12	24	< 2	3,7	350	n.a.
LTPR36/UV385	UV, 385 nm	12	24	< 2	3,7	350	n.a.
LTPR36/UV405	UV, 405 nm	12	24	< 2	3,7	350	n.a.





**3D OPTICS**

**LTPR SERIES**

The projection pattern can be easily integrated into the LTPR projection unit by unscrewing the retaining ring that holds the pattern itself. This simple procedure makes it easy to interchange different patterns on the same projection unit.

The pattern outer diameter is 21 mm, while the active projection area is a circle of 11 mm: all the significant features of the pattern are drawn inside such a circle. The projection area will show the same aspect ratio as the pattern. The projection accuracy depends both on the pattern manufacturing accuracy and lens distortion. The projection edge sharpness depends on both the lens resolution and the engraving technique: Laser-engraved patterns (part numbers ending in "L") or Photolithography-engraved patterns (part numbers ending in "P") can be chosen depending on the type of application.

# Pattern selection

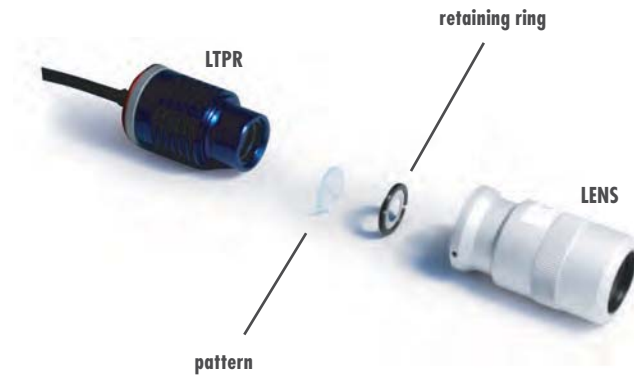

**STANDARD PATTERN**

photolithography patterns		laser engraved patterns	
<b>Substrate</b>	soda lime glass	<b>Substrate</b>	borofloat glass
<b>Coating</b>	Chrome	<b>Coating</b>	dichroic mirror
<b>Geometrical accuracy</b>	2 micron	<b>Geometrical accuracy</b>	50 micron
<b>Edge Sharpness</b>	1.4 micron	<b>Edge Sharpness</b>	50 micron

**CUSTOM-MADE PATTERN**

Custom-made patterns suitable for specific needs can be supplied on request. A drawing with all the significant geometrical information must be submitted (please refer to the instructions here below).

<p>P/N: PT00000100P line pattern</p>	<p>P/N: PT00000100L line pattern</p>
<p>P/N: PT00000200P cross pattern</p>	<p>P/N: PT00000200L cross pattern</p>
<p>P/N: PT00000300P stripe pattern</p>	<p>P/N: PT00000300L stripe pattern</p>
<p>P/N: PT00000400P grid pattern</p>	<p>P/N: PT00000400L grid pattern</p>
<p>P/N: PT00000500P edge pattern</p>	<p>P/N: PT00000500L edge pattern</p>

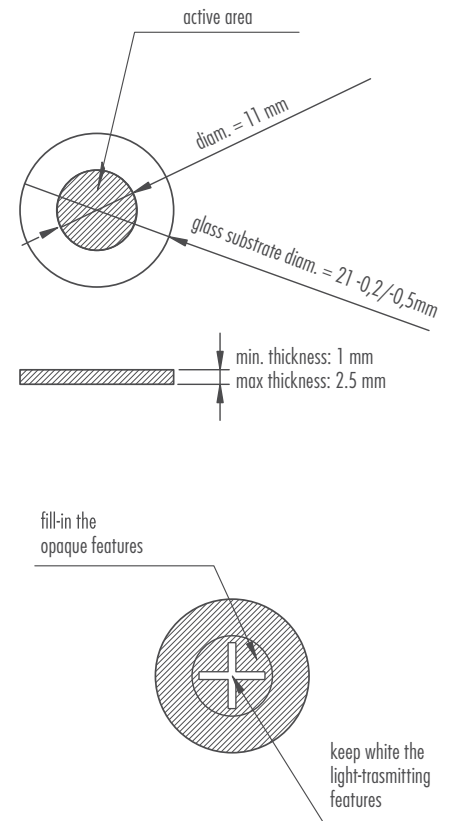



## LTPR SERIES

## 3D OPTICS

# Projection lens selection

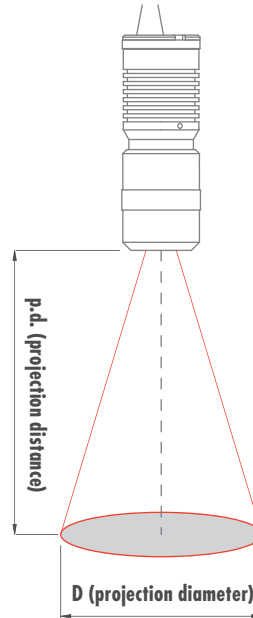
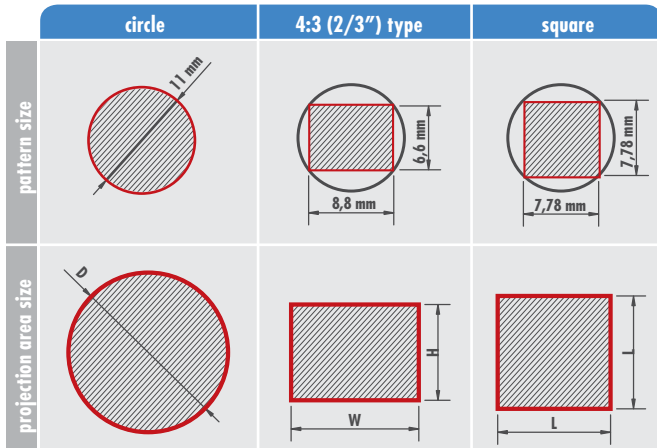

The pattern drawing that has to be projected must be inscribed in a circle whose diameter is 11 mm, same diagonal of a 2/3" detector.

For example, the pattern drawing could cover the entire 11 mm diameter area or be like a 8.8 x 6.6 mm rectangle (same size of a 2/3" detector) or, again, be a square whose side is 7.78 mm.

Unless the projection optics introduces significant distortion, the shape of the projection respects the same features and aspect ratio of the engraved area of the pattern. The projected area dimensions will be "M" times the original dimensions of the pattern, where M is the optical magnification at which the selected projection lens is operating.

LTPR units can integrate most types of high resolution lenses. Besides our OEPL optics, specifically tailored for this projection application, any high resolution C-mount lens can be used, provided it is tailored for 2/3" detectors (11 mm image diagonal). Telecentric lenses for 2/3" detector can also be interfaced, thus providing a parallel projection of the pattern scheme and enabling unparalleled performances in 3D measurement applications. C-mount lenses and telecentric optics can be connected to the unit by means of the mount adaptor included in the product package. Here below are listed the projection diameters and the recommended projection distances achievable by means of different types of optics.



### OEPL projection optics

OEPL lens	lens description	minimum projection distance (p.d.) (mm)	maximum projection distance (p.d.) (mm)
<b>VIS PROJECTION OPTICS</b>			
OEPL18	18° projection, full angle	300	800
OEPL25	25° projection, full angle	250	600
OEPL38	38° projection, full angle	200	500
OEPL50	50° projection, full angle	100	300
<b>UV PROJECTION OPTICS</b>			
PEB2528-UV	25° projection, full angle	250	500

### Telecentric lenses

VIS	TC 23 04	TC 23 07	TC 23 09	TC 23 16	TC 23 24	TC 23 36
p.d. (mm)	57,1	61,2	63,3	45,3	69,2	103,5
D (mm)	5,5	8,3	11,0	20,8	31,4	45,2
VIS	TC 23 48	TC 23 56	TC 23 64	TC 23 72	TC 23 80	TC 23 96
p.d. (mm)	134,6	159,3	182,3	227,7	227,7	279,6
D (mm)	59,8	70,0	80,0	89,9	99,7	117,8
UV	TCUV2336	TCUV2348	TCUV2356	TCUV2364	TCUV2380	
p.d. (mm)	98,7	130,7	154,0	176,0	221,0	
D (mm)	45,7	60,0	70,1	80,1	99,6	

### 2/3" C-mount lenses

C-mount Lens	D (mm)								
	@50 mm	@75 mm	@100 mm	@150 mm	@200 mm	@250 mm	@300 mm	@400 mm	@500 mm
6 mm	81	127	172	264					
8 mm	58 (*)	92	127	195	264	333			
12 mm	35 (*)	58 (*)	81	127	172	218	264		
16 mm		41 (*)	58 (*)	92 (*)	127	161	195	264	333
25 mm				55 (*)	77 (*)	99 (*)	121 (*)	165	209 (*)
35 mm						68 (*)	83 (*)	115	146

(\*) = spacers maybe needed to compensate back focal length